

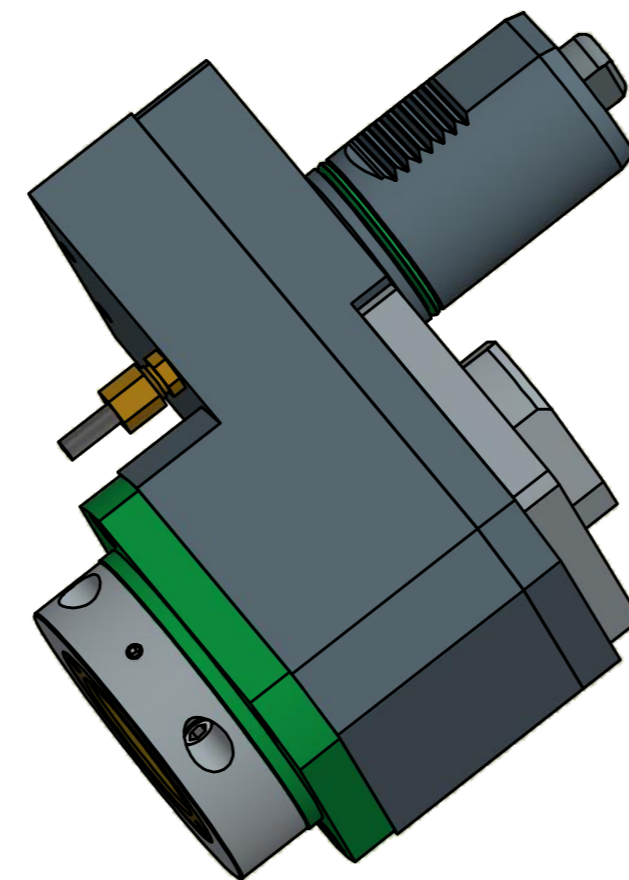

Varia V5

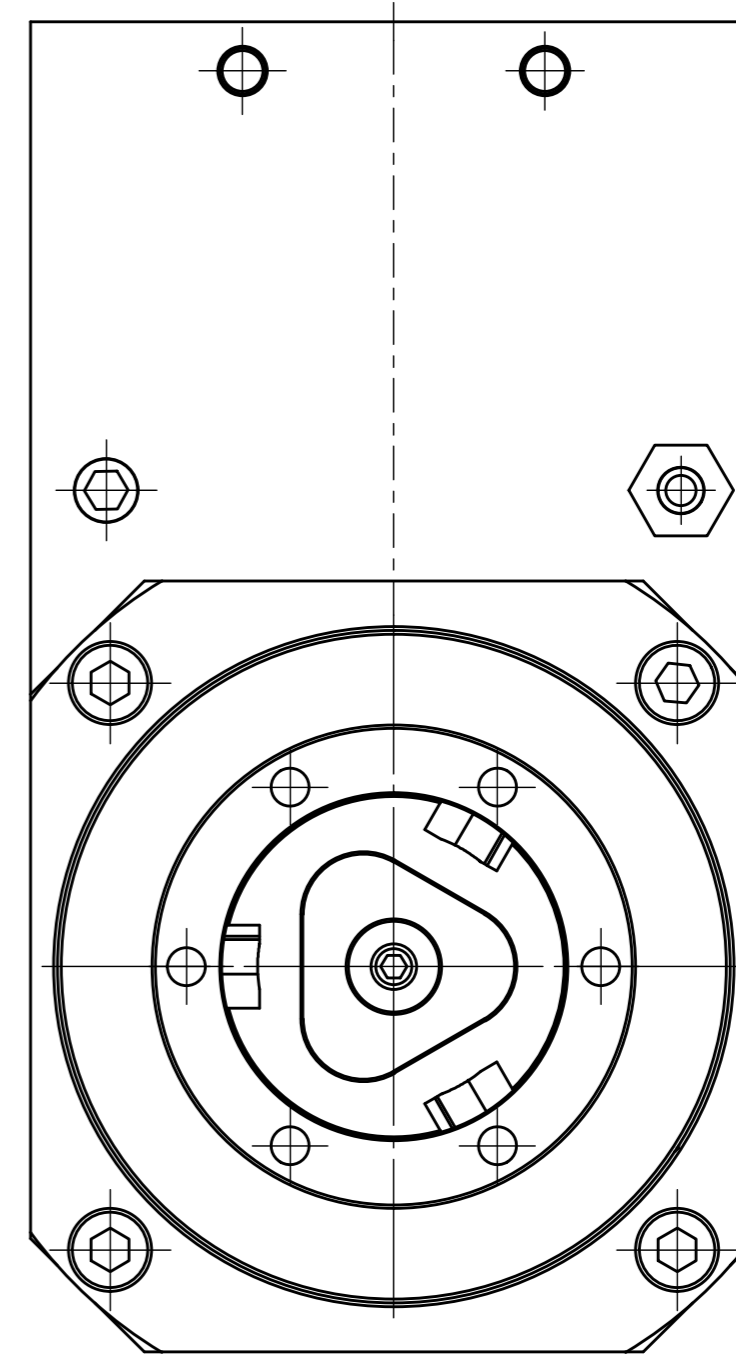
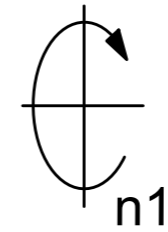
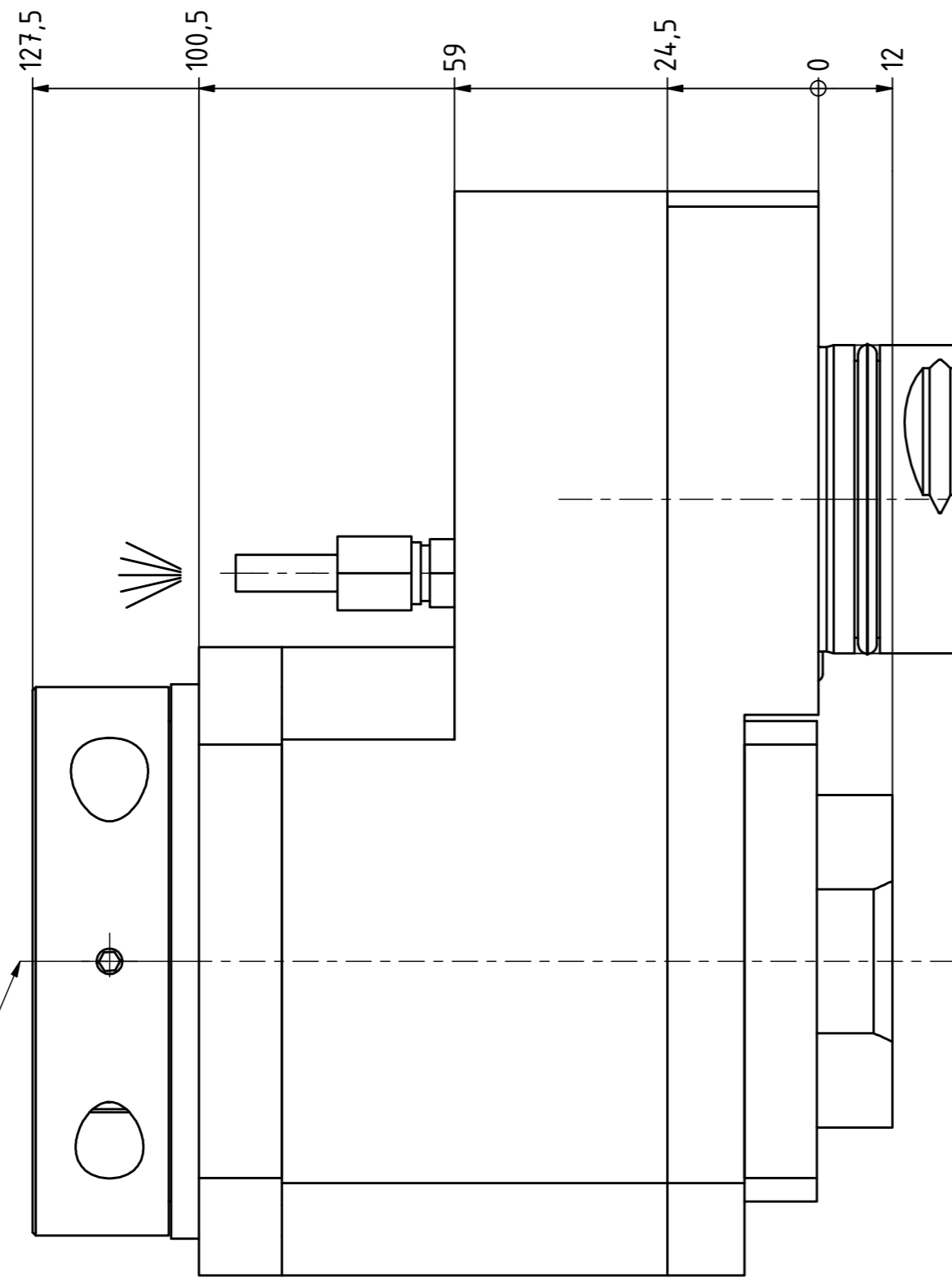

Copyright **EWS Tool Technologies**  
 Weitergabe und Vervielfältigung dieser Unterlage,  
 Verwertung und Mitteilung ihres Inhalts nicht  
 gestattet, soweit nicht ausdrücklich zugestanden.  
 Zuwiderhandlungen verpflichten zu Schadenersatz.

Bemerkung - Note	Technische Daten - technical data <b>Weight</b> = 10.903 [kg] <b>Torque max. (M1/M2)</b> = 100 / 100 [Nm] <b>Speed max. (n1/n2)</b> = 4000 / 4000 [1/min] <b>Gear ratio (i)=n1:n2</b> = 1:1	Benennung - Title <b>Axial Bohr u. Fräskopf achsversetzt</b> <i>Ax. drill. and mill. head offset</i>	 <b>EWS</b> Weigle GmbH & Co. KG Maybachstr. 1 D-73066 Uhingen www.ews-tools.de	Technische Änderungen vorbehalten! <i>Subject to technical modifications!</i> IDENT: D-EWS-014213 REV: -/- MNR.	 <b>QR</b> 133385
------------------	---	--	---	---	--