

W-Verzahnung Lizenz Index-Werke
W-tooth system licence Index-Corporation

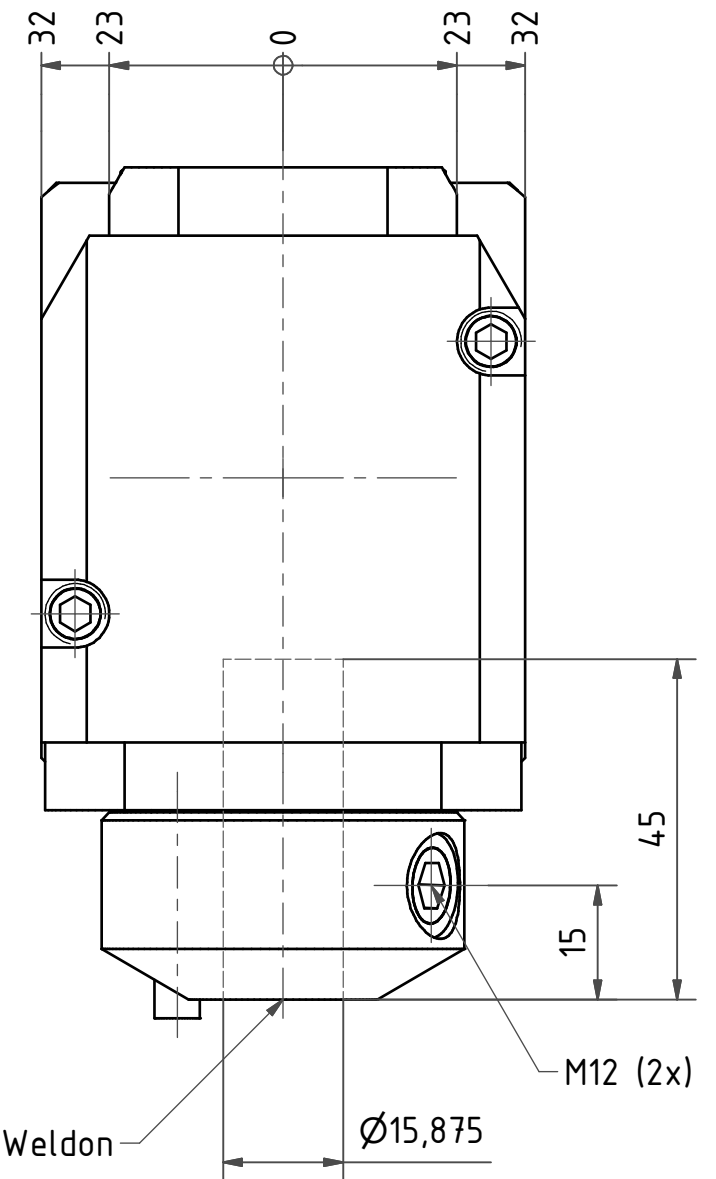

Whistle Notch / Weldon

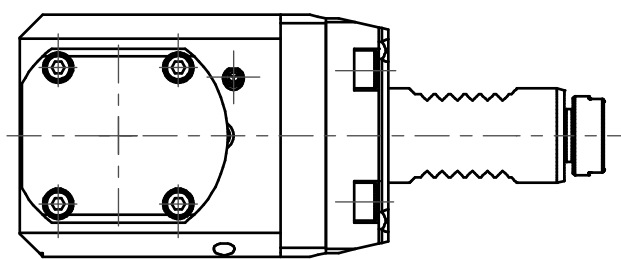

Doppelverzahnung Lizenz Traub
double tooth system licence Traub

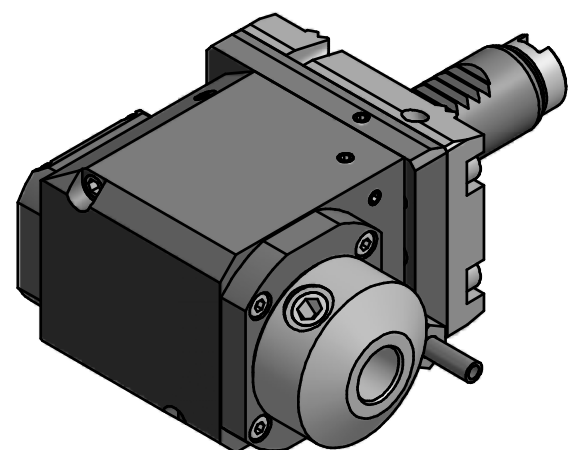

Copyright **EWS Tool Technologies**
 Weitergabe und Vervielfaeltigung dieser Unterlage,
 Verwertung und Mitteilung ihres Inhalts nicht
 gestattet, soweit nicht ausdrecklich zugestanden.
 Zuwiderhandlungen verpflichten zu Schadenersatz.

Bemerkung - Note	Technische Daten - technical data $M_1 / M_2 = 20 / 40 \text{ Nm}$ $n_1 / n_2 = 6000 / 3000 \text{ 1/min}$ $i (N_1:N_2) = 2:1$	Benennung - Title Radial Bohr und Fräskopf <i>Radial drilling and milling head</i>	name	date	Technische Aenderungen vorbehalten! <i>Subject to technical modifications!</i>	
			drawing	22.12.2006		
			EWS Weigete GmbH & Co. KG Maybachstr. 1 D-73066 Uhingen Tel. +49(0)7161/93040-100		Nr. 60.2515.88WNG200RLI2W	DIN A3
			MNR: 131490		IDENT: D-EWS-007308 -	Blatt - page 1 (1)