

min. 80,5
max. 84

Spannzange / collet ER25 DIN6499
Spannbereich / clamping range: 1,0 - 16,0

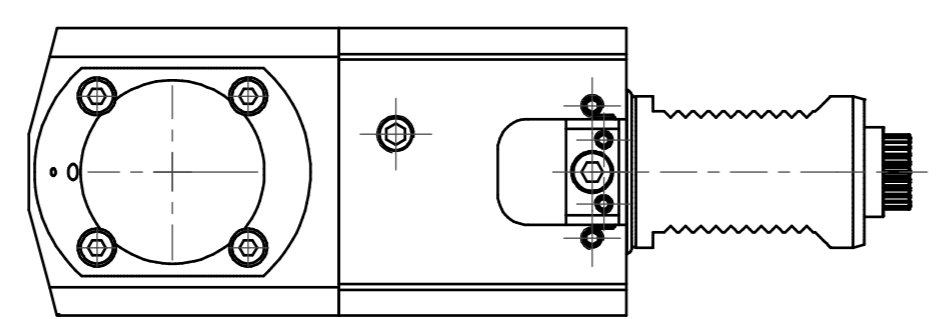

Doppelverzahnung Lizenz Traub
double tooth system licence Traub

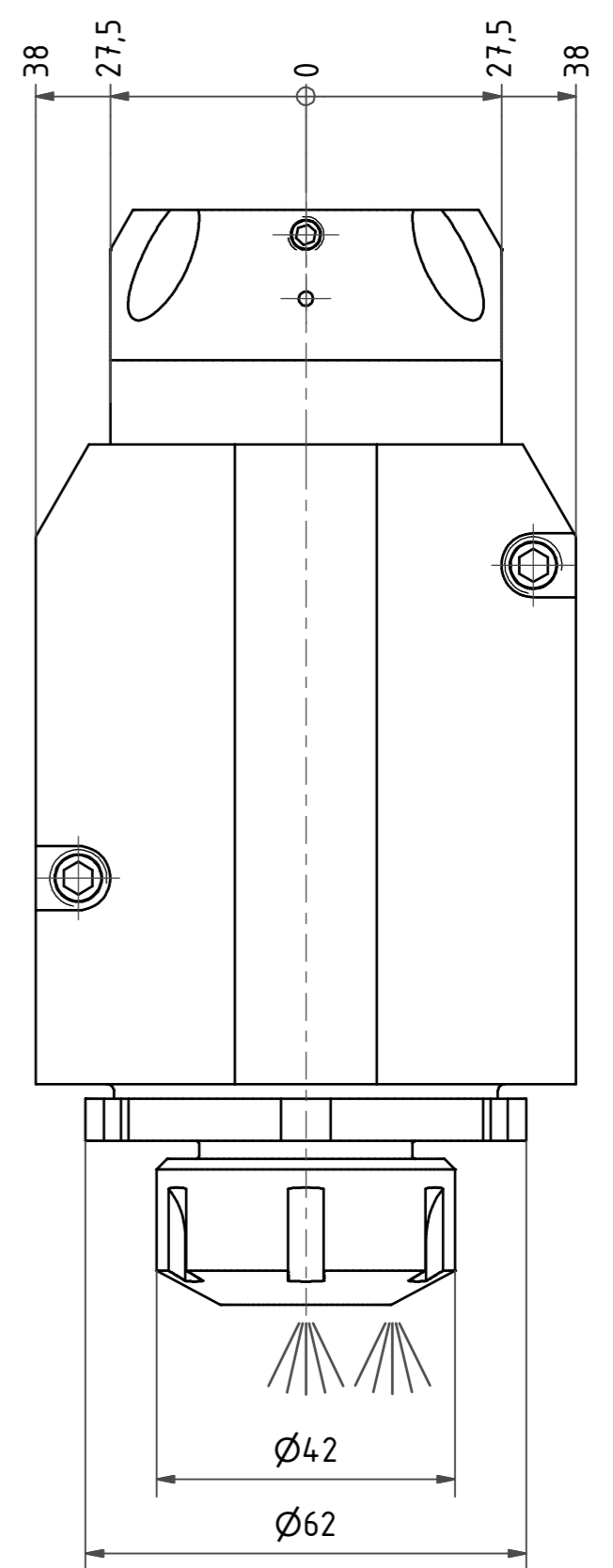
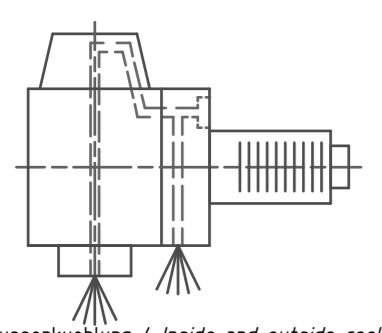
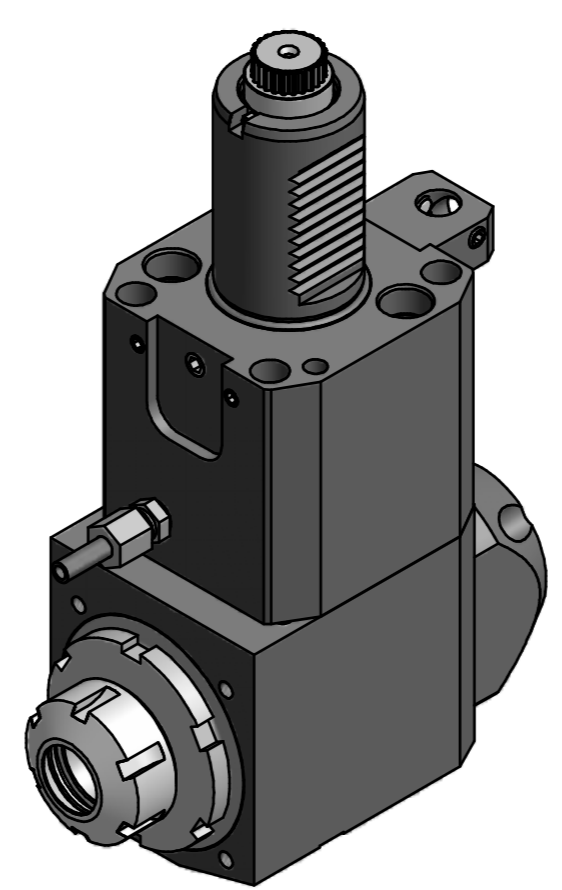

Innen- und Aussenkuehlung / Inside and outside coolant supply
Kein Trockenlauf / No dry run
Kuehlmittelfiltrierung=50µ / coolant filtration=50µ

Bemerkung - Note
Nicht ohne Kuehlmittel betreiben!
Not for use without coolant-fluid!

Technische Daten - Technical data
M1 / M2 = 50 / 25 Nm
n1 / n2 = 6000 / 12000 1/min
i (N1:N2) = 1:2
Pmax = 25 bar

Benennung - Title
Radial Bohr und Fräskopf
Radial drilling and milling head

name	date	Technische Aenderungen vorbehalten! Subject to technical modifications!
D.Sadoroschni	03.04.2009	
 Weigle GmbH & Co. KG Maybachstr. 1 D-70664 Uhlringen Tel. +49(0)7161/93040-10		Nr. 60.4025LCTXRLIK1 File: D-EWS-074181.idw
DIN A2		Blatt - page 1 (1)

Copyright **EWS Tool Technologies**
Weitergabe und Vervielfaeltigung dieser Unterlage,
Verwertung und Mitteilung ihres Inhalts nicht
gestattet, soweit nicht ausdrecklich zugestanden.
Zuwaenderungen verpflichten zu Schadenersatz.