

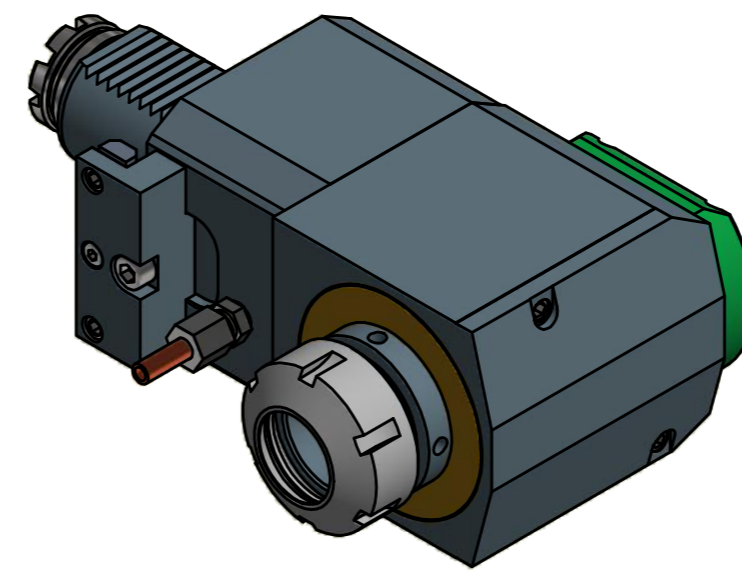

Spannzange / collet ER32 DIN6499  
 Spannbereich / clamping range: 2,0 - 20,0

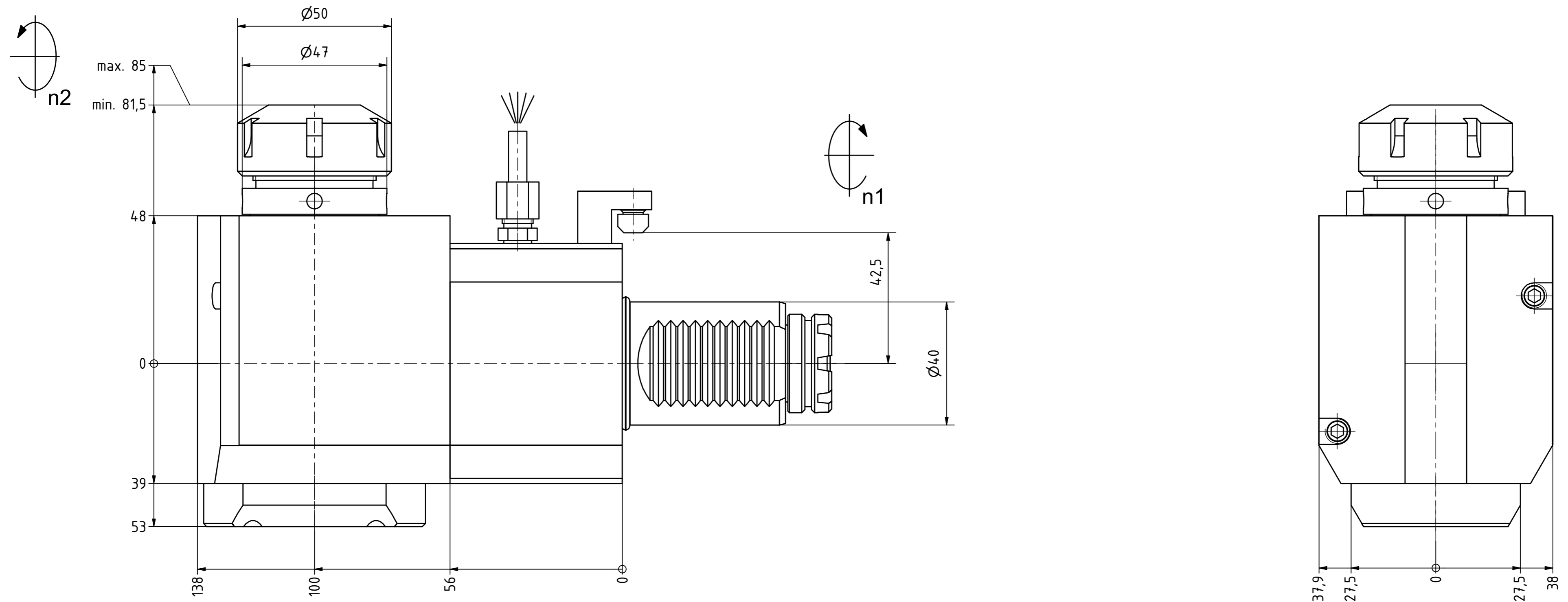

Copyright **EWS Tool Technologies**  
 Weitergabe und Vervielfältigung dieser Unterlage,  
 Verwertung und Mitteilung ihres Inhalts nicht  
 gestattet, soweit nicht ausdrücklich zugestanden.  
 Zuwiderhandlungen verpflichten zu Schadenersatz.

Bemerkung - Note	Technische Daten - technical data Weight = 6.469 [kg] Torque max. (M1/M2) = 50 / 50 [Nm] Speed max. (n1/n2) = 6000 / 6000 [1/min] Gear ratio (i)=n1:n2 = 1:1	Benennung - Title Radial Bohr und Fräskopf Radial drilling and milling head	<table border="1"> <tr> <td data-bbox="2249 1927 2463 1984"> <b>EWS</b>                      Tool Technologies  <small>EWS Weigle GmbH &amp; Co. KG                      Maybachstr. 1                      D-73066 Uhingen                      www.ews-tools.de</small> </td> <td data-bbox="2472 1927 2781 1984">                     Technische Änderungen vorbehalten!                      Subject to technical modifications!                      IDENT: DEWS112660                      REV: -/A                 </td> </tr> <tr> <td data-bbox="2249 1990 2686 2041">                     Nr. - No.                      60.4032LTOEMLX100                 </td> <td data-bbox="2694 1990 2781 2041">                     MNR.                      132566                 </td> </tr> </table>	<b>EWS</b> Tool Technologies <small>EWS Weigle GmbH &amp; Co. KG                      Maybachstr. 1                      D-73066 Uhingen                      www.ews-tools.de</small>	Technische Änderungen vorbehalten! Subject to technical modifications! IDENT: DEWS112660 REV: -/A	Nr. - No. 60.4032LTOEMLX100	MNR. 132566	
<b>EWS</b> Tool Technologies <small>EWS Weigle GmbH &amp; Co. KG                      Maybachstr. 1                      D-73066 Uhingen                      www.ews-tools.de</small>	Technische Änderungen vorbehalten! Subject to technical modifications! IDENT: DEWS112660 REV: -/A							
Nr. - No. 60.4032LTOEMLX100	MNR. 132566							