

Spannzange / collet ER40 DIN6499  
Spannbereich / clamping range: 3,0 - 26,0

Gewindebohrzange / tapping collet  
ET-1-40 M6-M16

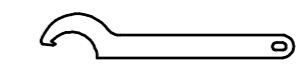

Hakenschlüssel  
mit Nase  
Hook wrench with  
nose end  
DIN1810 A 58x62

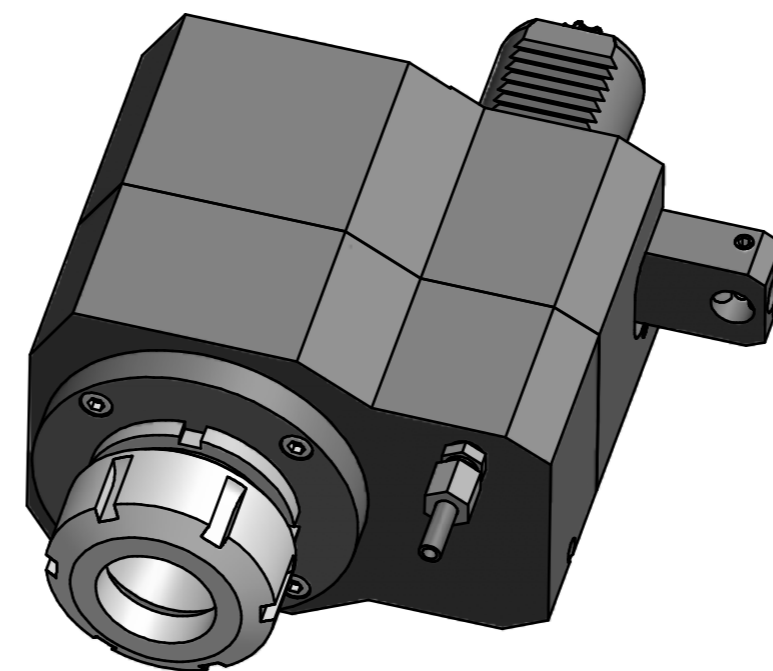
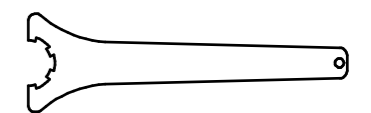

Spannzangenschlüssel  
Clamping wrench  
240

Copyright **EWS Tool Technologies**  
Weitergabe und Vervielfältigung dieser Unterlage,  
Verwertung und Mitteilung ihres Inhalts nicht  
gestattet, soweit nicht ausdrücklich zugestanden.  
Zuwendungen verpflichten zu Schadenersatz.

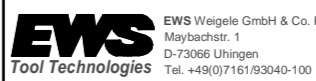
Bemerkung - Note	Technische Daten - Technical data M <sub>1</sub> / M <sub>2</sub> = 40 / 120 Nm n <sub>1</sub> / n <sub>2</sub> = 6000 / 2000 1/min i (N <sub>1</sub> :N <sub>2</sub> ) = 2,895:1	Benennung - Title <b>Axial Bohr u. Fräskopf achsversetzt</b> <b>Ax. drill. and mill. head offset</b>	name	date	Technische Änderungen vorbehalten! Subject to technical modifications!	
			drawing	24.01.2007		
			 <b>EWS</b> Werkzeug GmbH & Co. KG <small>Maybachstr. 1 D-73066 Ulm/Gen Tel. +49(0)7161/93040-100</small>		Nr. <b>50.40405482LI3</b>	
			MNR: 133323		IDENT: D-EWS-001891 - Blatt - page 1 (1)	