

Fraeserwelle austauschbar  
Spindle removable

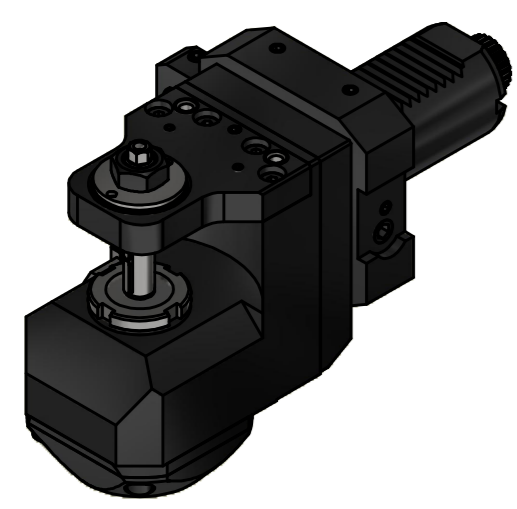
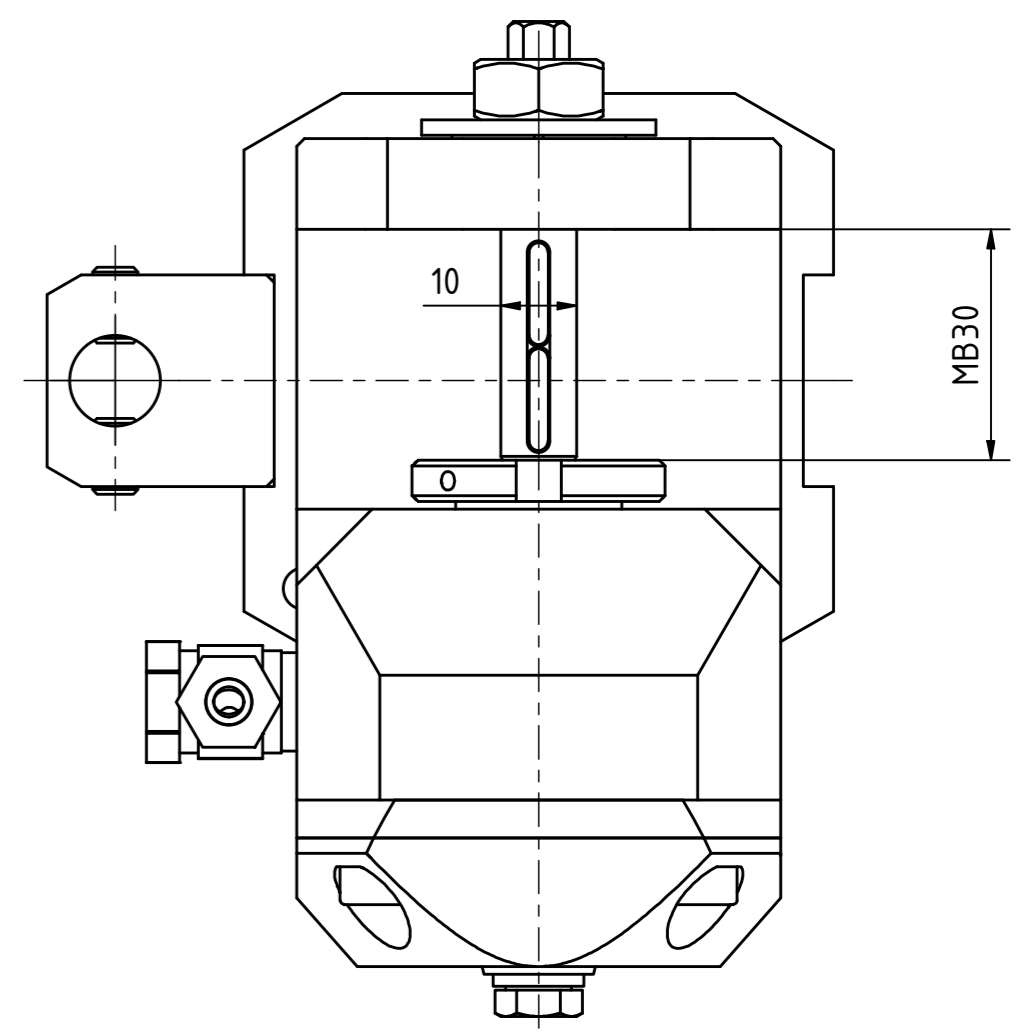
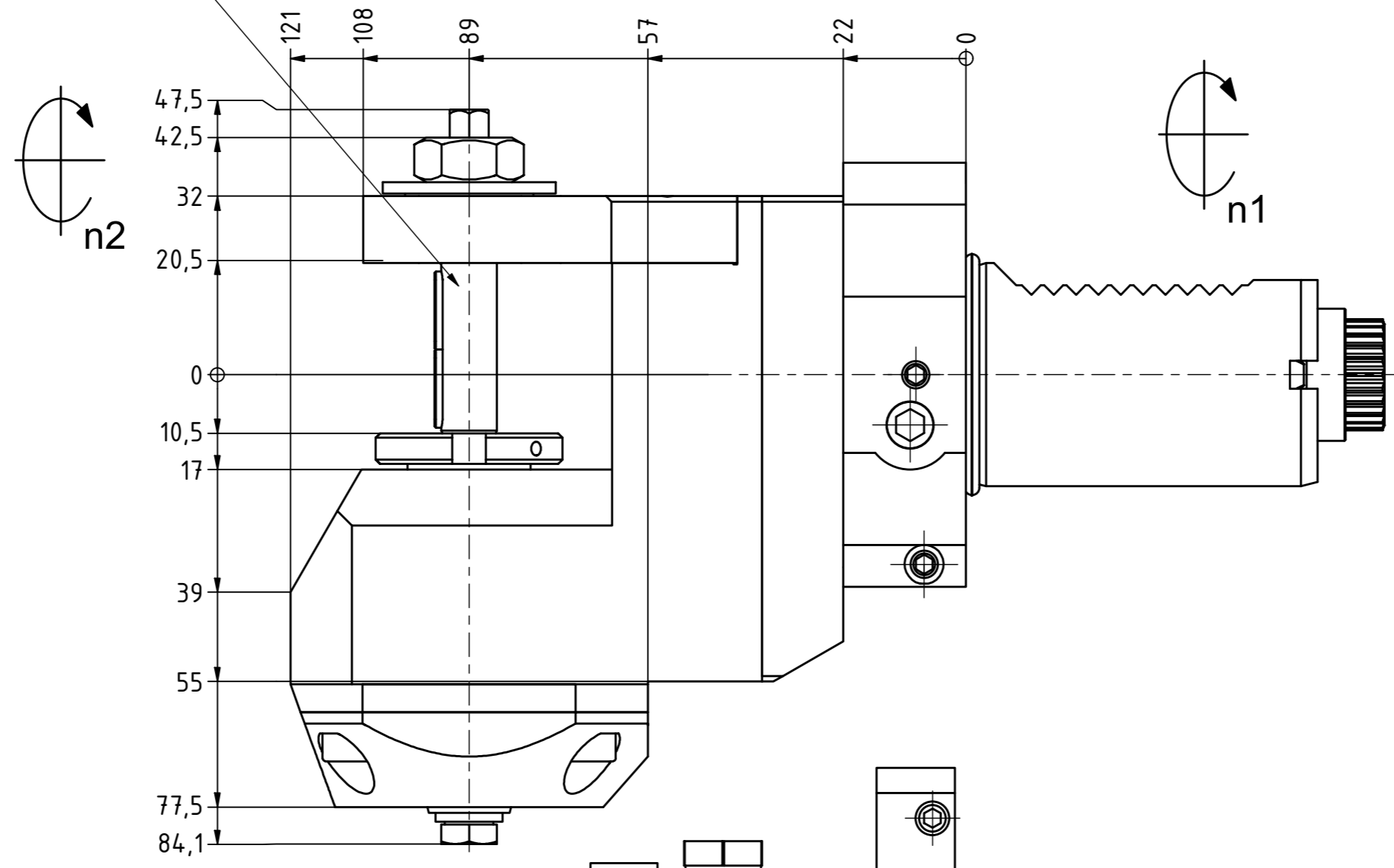
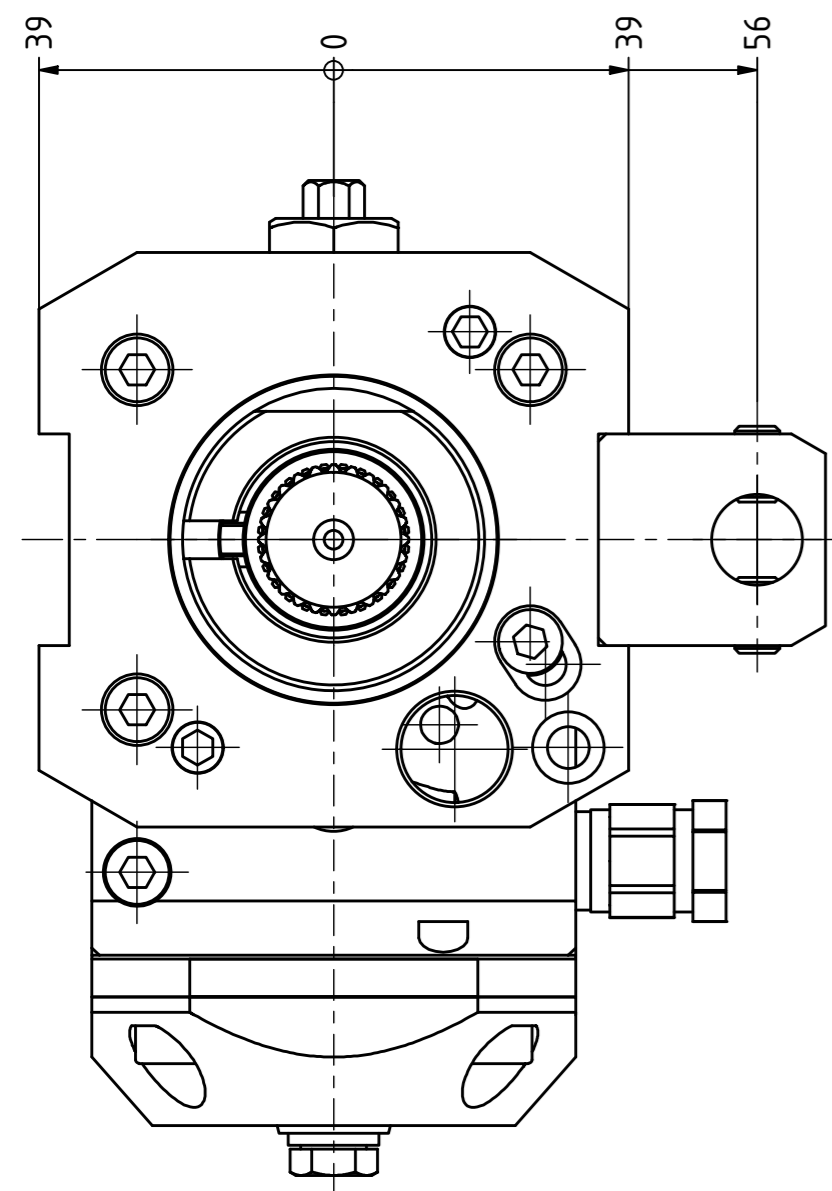

max. Fraeser-Ø80

max. Fraeserdurchmesser 80mm  
max. saw milling diameter 80mm

Copyright **EWS Tool Technologies**  
Weitergabe und Vervielfältigung dieser Unterlage,  
Verwertung und Mitteilung ihres Inhalts nicht  
gestattet, soweit nicht ausdrücklich zugestanden.  
Zuwendungen verpflichten zu Schadenersatz.

Bemerkung - Note 	Technische Daten - technical data Weight = 4,585 [kg] Torque max. (M1/M2) = 20 / 60 [Nm] Speed max. (n1/n2) = 6000 / 2000 [1/min] Gear ratio (i)=n1:n2 = 3:1	Benennung - Title <b>Scheibenfräserkopf</b> <b>Radial saw milling head</b>	<b>EWS</b> Tool Technologies <small>EWS Weigle GmbH &amp; Co. KG Maybachstr. 1 D-73066 Ultingen www.ews-tool.de</small>	Technische Änderungen vorbehalten! Subject to technical modifications! IDENT: D-EWS-005138 REV: -/B MNR:	Nr. - No. <b>64.4010CTX13-BG30</b> <b>132545</b> 
----------------------	--	--	--	--	---