

Spannzange / collet ER50 DIN6499
 Spannbereich / clamping range: 6,0 - 34,0

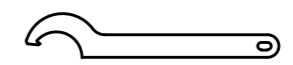

Hakenschlüssel
 mit Nase
 Hook wrench with
 nose end
 DIN1810 A 80x90

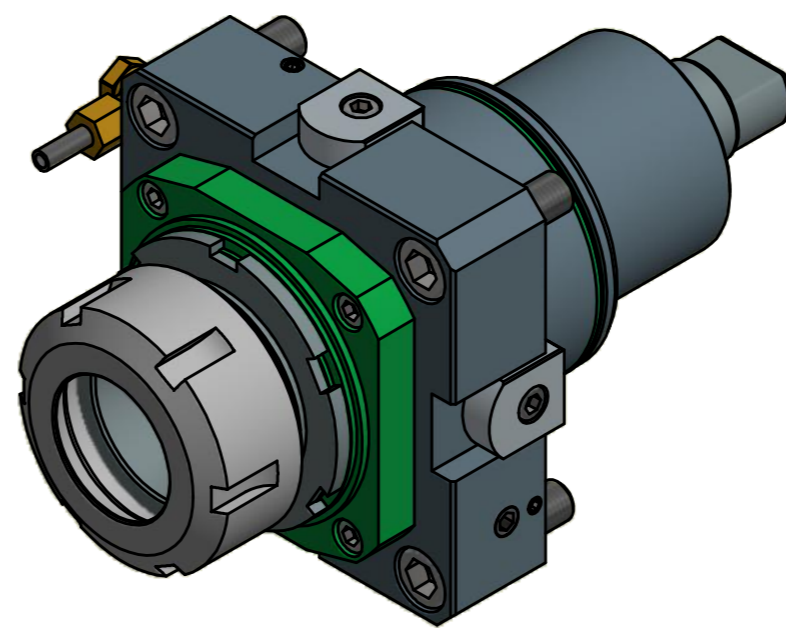
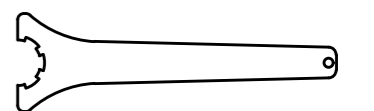

Spannzangenschlüssel
 Clamping wrench
 250

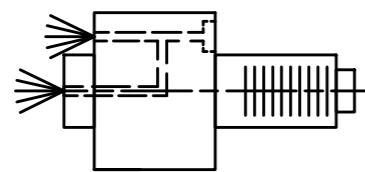

Innen- und Aussenkuehlung / Inside and outside coolant supply
 Kein Trockenlauf / No dry run
 Kuehlmittelfiltrierung-50µ / coolant filtration-50µ

Bemerkung - Note
 Nicht ohne Kuehlmittel betreiben!
 Not for use without coolant-fluid!

Technische Daten - technical data
 Weight = 8.659 [kg]
 Torque max. (M1/M2) = 100 / 100 [Nm]
 Speed max. (n1/n2) = 4000 / 4000 [1/min]
 Gear ratio (i)=n1:n2 = 1:1
 Pressure (pmax) = 25 [bar]

Benennung - Title
 Axial Bohr und Fräskopf
 Axial drilling and milling head

EWS Tool Technologies
 EWS Weigle GmbH & Co. KG
 Maybachstr. 1
 D-73066 Uhlingen
 www.ews-tool.de

Technische Aenderungen vorbehalten!
 Subject to technical modifications!
 IDENT: DEWS053056

REV: -/B
 MNR.
 133882



Copyright **EWS Tool Technologies**
 Weitergabe und Vervielfaeltigung dieser Unterlage,
 Verwertung und Mitteilung ihres Inhalts nicht
 gestattet, soweit nicht ausdrecklich zugestanden.
 Zuwiderhandlungen verpflichten zu Schadenersatz.