

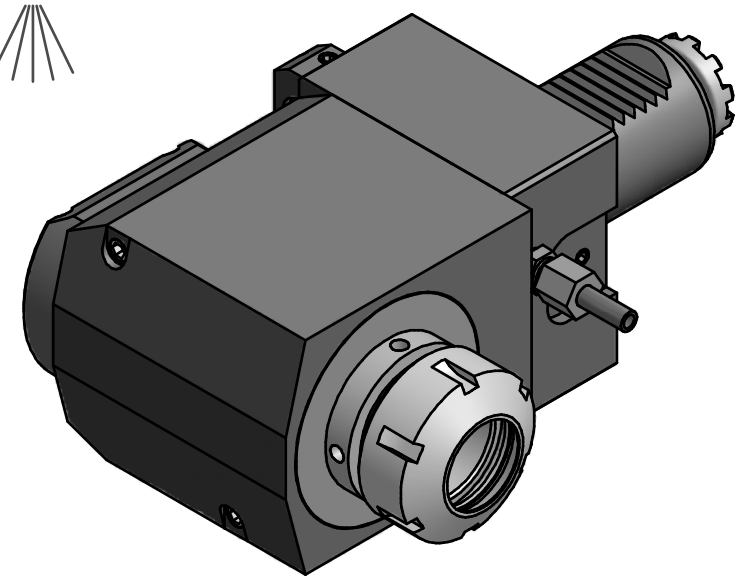

Spannzange / collet ER32 DIN6499  
 Spannbereich / clamping range: 2,0 - 20,0

Gewindebohrzange / tapping collet  
 ET-1-32 M5-M12



  
 Hakenschlüssel  
 mit Zapfen  
 Hook wrench  
 with fixed pin  
 DIN1810 B 45x50

  
 Spannzangenschlüssel  
 Clamping wrench  
 232

Copyright **EWS Tool Technologies**  
 Weitergabe und Vervielfaeltigung dieser Unterlage,  
 Verwertung und Mitteilung ihres Inhalts nicht  
 gestattet, soweit nicht ausdrecklich zugestanden.  
 Zuwiderhandlungen verpflichten zu Schadenersatz.

Bemerkung - Note  	Technische Daten - technical data M1 / M2 = 50 / 50 Nm n1 / n2 = 6000 / 6000 1/min i (N1:N2) = 1:1	Benennung - Title <b>Radial Bohr und Fräskopf</b> <i>Radial drilling and milling head</i>	<table border="1"> <tr> <td>name</td> <td>date</td> </tr> <tr> <td>Theiss</td> <td>25.09.2012</td> </tr> </table>  Weigele GmbH & Co. KG Maybachstr. 1 D-73066 UHINGEN Tel. +49(0)7161/93040-10	name	date	Theiss	25.09.2012	Technische Aenderungen vorbehalten! Subject to technical modifications! Nr. <b>60.4032BSARX95</b> File: D-EWS-126226-.idw Blatt - page 1 (1)
name	date							
Theiss	25.09.2012							