

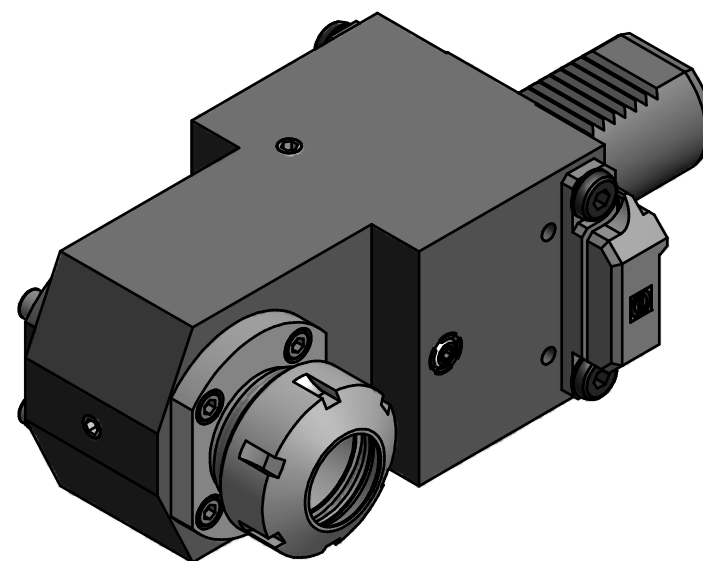



Spannzange / collet ER32 DIN6499
 Spannungsbereich / clamping range: 2,0 - 20,0

Gewindebohrzange / tapping collet
 ET-1-32 M5-M12

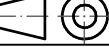

Copyright **EWS Tool Technologies**
 Weitergabe und Vervielfältigung dieser Unterlage,
 Verwertung und Mitteilung ihres Inhalts nicht
 gestattet, soweit nicht ausdrücklich zugestanden.
 Zuwiderhandlungen verpflichten zu Schadenersatz.

Bemerkung - Note	Technische Daten - technical data Weight = 6.743 [kg]	Benennung - Title Spannzangenaufnahme <i>Collet chuck holder</i>	 EWS Weigele GmbH & Co. KG Maybachstr. 1 D-73066 Uhingen www.ews-tools.de Nr. - No. 31.4032LCTXRTF	Technische Änderungen vorbehalten! Subject to technical modifications! IDENT: D-EWS-204364 MNR. S04988	 
------------------	--	---	---	---	---