

Spannzange / collet ER32 DIN6499  
 Spannbereich / clamping range: 2,0 - 20,0

Gewindebohrzange / tapping collet  
 ET-1-32 M5-M12

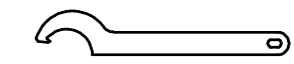

Hakenschlüssel  
 mit Nase  
 Hook wrench with  
 nose end  
 DIN1810 A 58x62

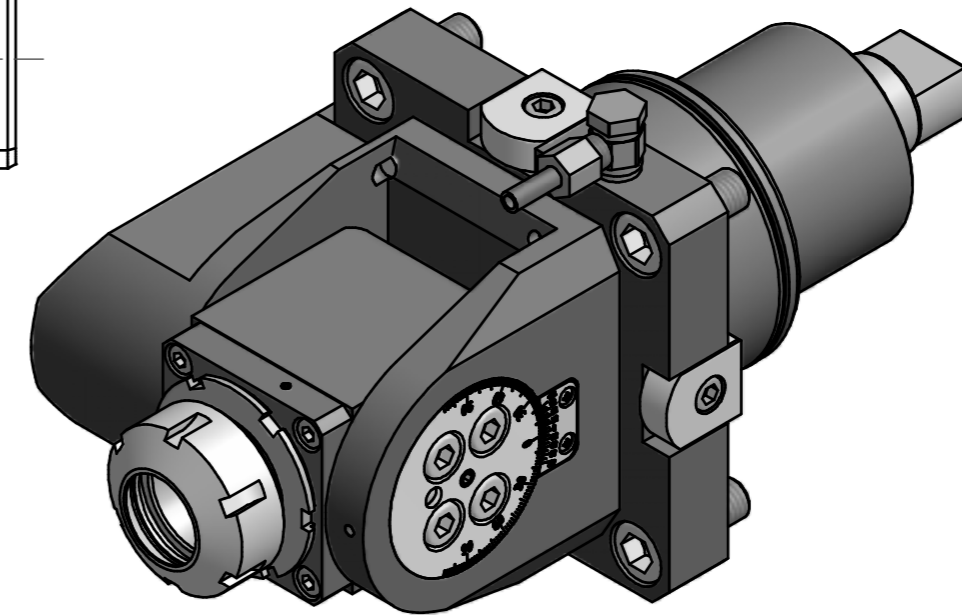
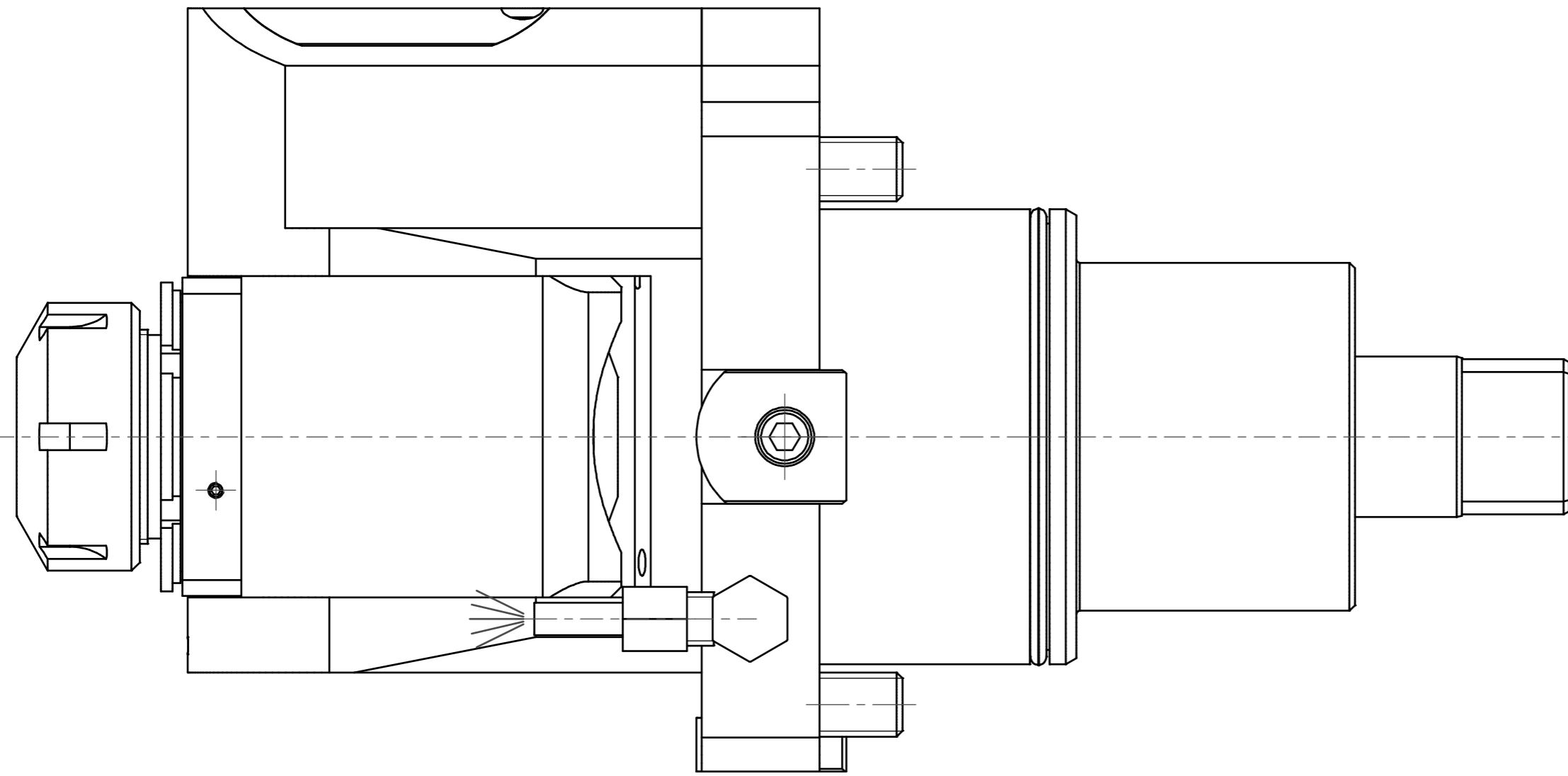
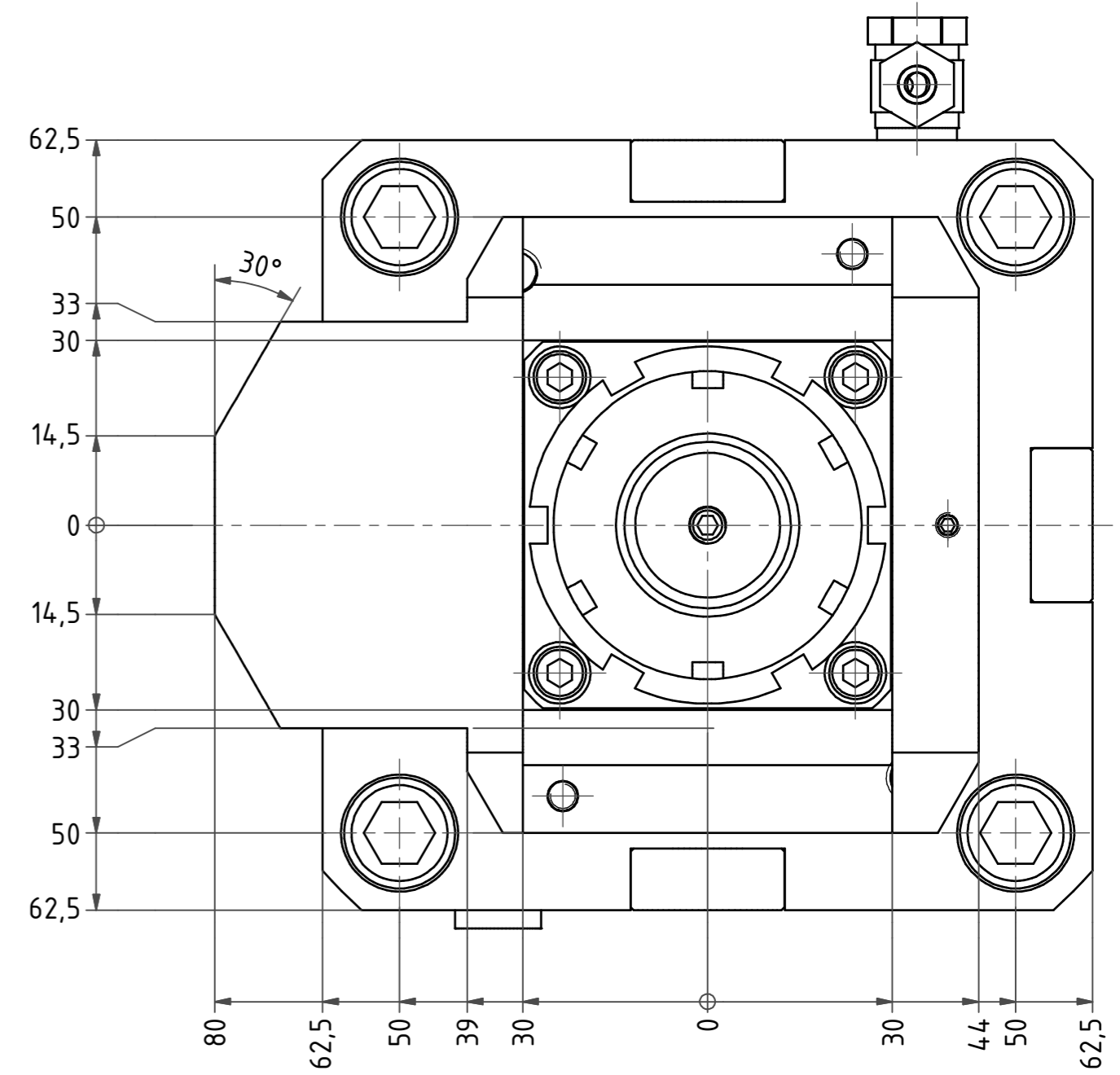
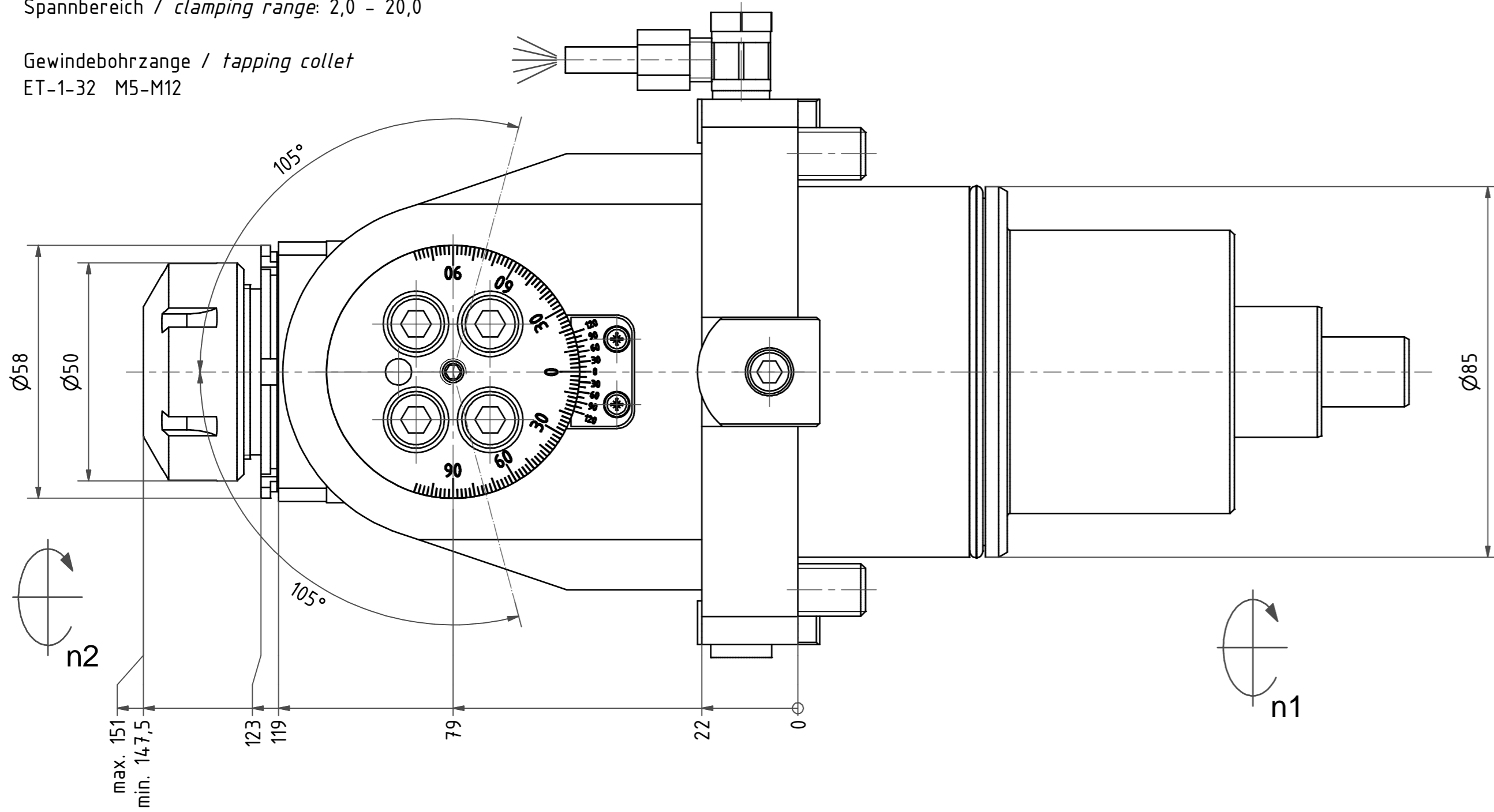
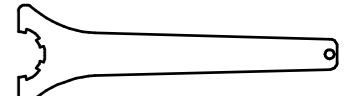

Spannzangenschlüssel  
 Clamping wrench  
 232

Copyright **EWS Tool Technologies**  
 Weitergabe und Vervielfältigung dieser Unterlage,  
 Verwertung und Mitteilung ihres Inhalts nicht  
 gestattet, soweit nicht ausdrücklich zugestanden.  
 Zuwiderhandlungen verpflichten zu Schadenersatz.

Bemerkung - Note

Technische Daten - Technical data

M<sub>1</sub> / M<sub>2</sub> = 50 / 50 Nm  
 n<sub>1</sub> / n<sub>2</sub> = 4000 / 4000 1/min  
 i (N<sub>1</sub>:N<sub>2</sub>) = 1:1

Benennung - Title

**Schwenkkopf**  
**Swivel head**

name date

drawing Votteler 27.11.2007

Technische Änderungen vorbehalten!  
 Subject to technical modifications!

Nr. 63.85321809



EWS Werkzeug GmbH & Co. KG  
 Maybachstr. 1  
 D-73066 Ulm/lingen  
 Tel. +49(0)7161/93040-100



DIN A2

MNR: 133195 IDENT: D-EWS-053590 B Blatt - page 1 (1)