

Spannzange / collet ER25 DIN6499
 Spannbereich / clamping range: 1,0 - 16,0

Gewindebohrzange / tapping collet
 ET-1-25 M3-M10

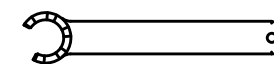

Spannzangenschlüssel für
 innenliegende Mutter
*Clamping wrench for
 internal collet*
 225AX

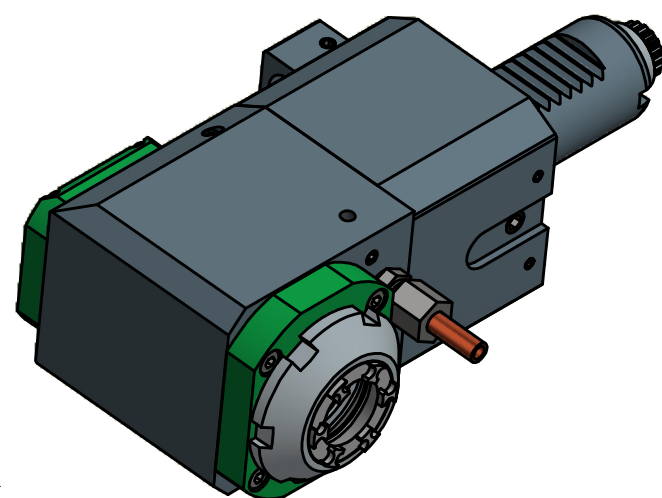
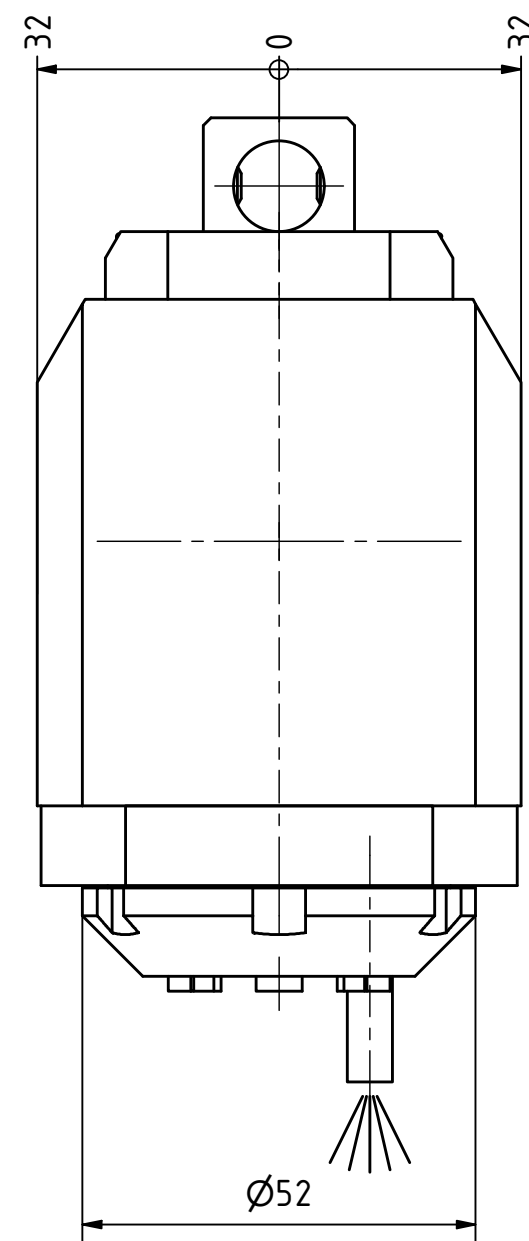
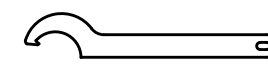

Hakenschlüssel
 mit Nase
*Hook wrench with
 nose end*
 DIN1810 A 52x55

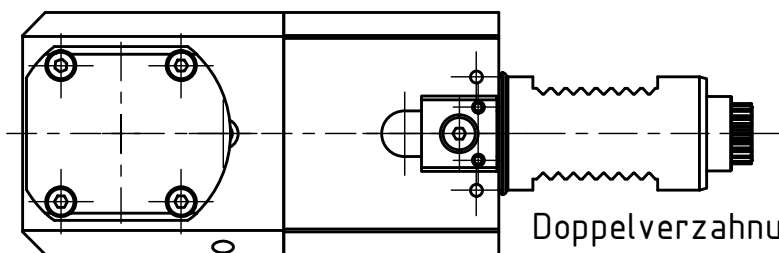

Doppelverzahnung Lizenz Traub
double tooth system licence Traub

Copyright **EWS Tool Technologies**
 Weitergabe und Vervielfältigung dieser Unterlage,
 Verwertung und Mitteilung ihres Inhalts nicht
 gestattet, soweit nicht ausdrücklich zugestanden.
 Zuwiderhandlungen verpflichten zu Schadenersatz.

Bemerkung - Note

Technische Daten - technical data

Weight = 4.015 [kg]
 Torque max. (M1/M2) = 25 / 25 [Nm]
 Speed max. (n1/n2) = 8000 / 8000 [1/min]
 Gear ratio (i)=n1:n2 = 1:1

Benennung - Title

Radial Bohr und Fräskopf
Radial drilling and milling head



Nr. - No.
60.3025LCTXRLIM

Technische Änderungen vorbehalten!
 Subject to technical modifications!

IDENT: D-EWS-003817

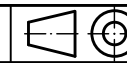

REV: -/A

MNR.

131624

