

W-Verzahnung Lizenz Index-Werke
 W-tooth system licence Index-Corporation

Spannzange / collet ER20 DIN6499
 Spannbereich / clamping range: 1,0 - 13,0

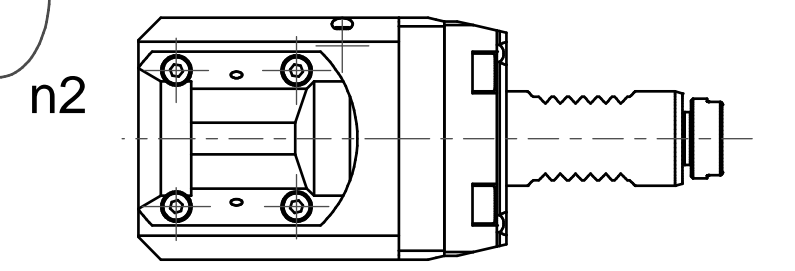

Doppelverzahnung Lizenz Traub
 double tooth system licence Traub

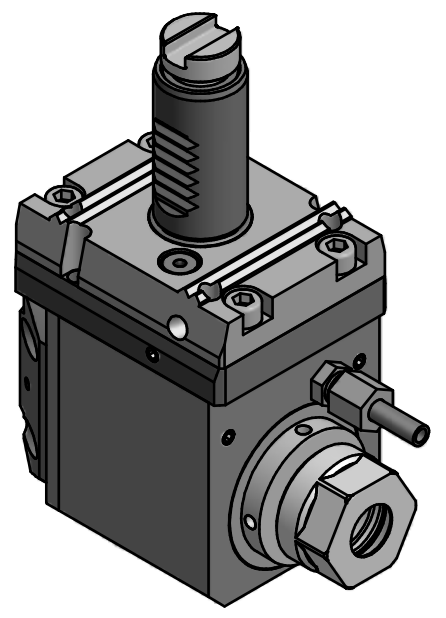

Hakenschlüssel
 mit Zapfen
 Hook wrench
 with fixed pin
 DIN1810 B 40x42

Copyright **EWS Tool Technologies**
 Weitergabe und Vervielfaeltigung dieser Unterlage,
 Verwertung und Mitteilung ihres Inhalts nicht
 gestattet, soweit nicht ausdruuecklich zugestanden.
 Zuwiderhandlungen verpflichten zu Schadenersatz.

<p>Bemerkung - Note Nicht ohne Kuehlmittel betreiben! Not for use without coolant-fluid!</p>	<p>Technische Daten - technical data M1 / M2 = 20 / 40 Nm n1 / n2 = 6000 / 3000 1/min i (N1:N2) = 2:1 pmax = 70 bar</p>	<p>Benennung - Title Radial Bohr und Fräskopf Radial drilling and milling head</p>	<table border="1"> <tr> <td>name</td> <td>date</td> </tr> <tr> <td>drawing</td> <td>08.01.2007</td> </tr> </table> <p>EWS Tool Technologies Weigele GmbH & Co. KG Maybachstr. 1 D-73066 UHINGEN Tel. +49(0)7161/93040-10</p>	name	date	drawing	08.01.2007	<p>Technische Aenderungen vorbehalten! Subject to technical modifications!</p> <p>Nr. 60.2520G200RLIKI2W</p> <p>File: 60.2520G200RLIKI2W_OUT.idw</p> <p>DIN A3 Blatt - page 1 (1)</p>
name	date							
drawing	08.01.2007							