

Spannzange / collet ER25 DIN6499  
 Spannbereich / clamping range: 1,0 - 16,0

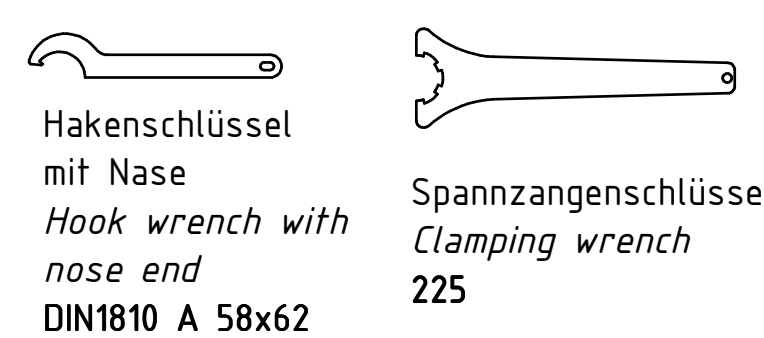
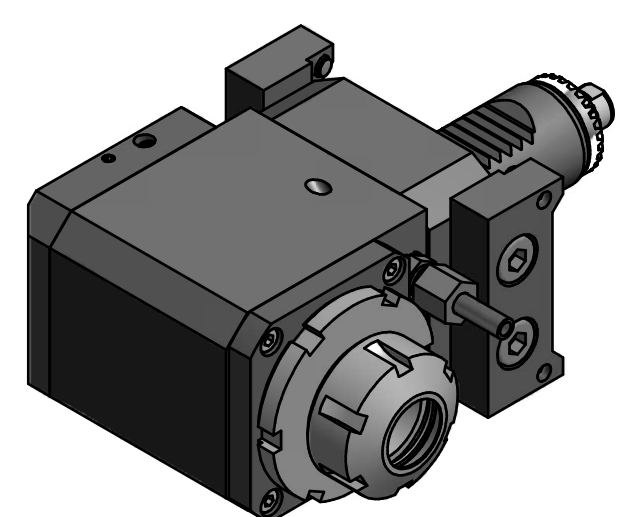
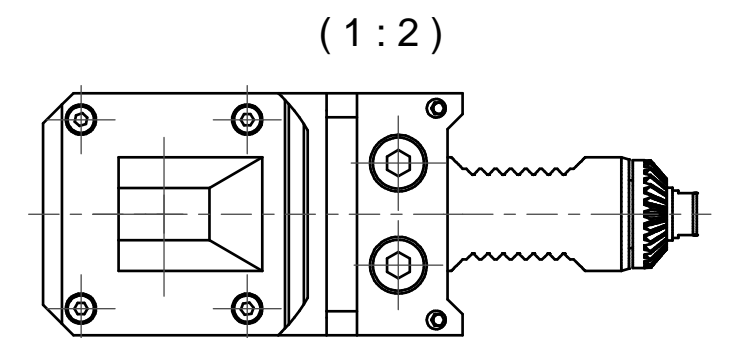
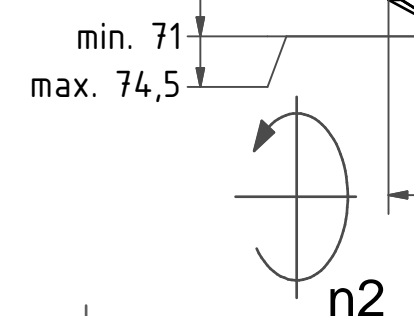

Innen- und Aussenkuehlung / Inside and outside coolant supply  
 Kein Trockenlauf / No dry run  
 Kuehlmittelfiltrierung <math>< 50\mu</math> / coolant filtration <math>< 50\mu</math>

mit Kegelrollenlager  
 with taper roller bearing(s)

Doppelverzahnung Lizenz Traub  
 double tooth system licence Traub

Hakenschlüssel  
 mit Nase  
 Hook wrench with  
 nose end  
 DIN1810 A 58x62

Spannzangenschlüssel  
 Clamping wrench  
 225

Copyright **EWS Tool Technologies**  
 Weitergabe und Vervielfaeltigung dieser Unterlage,  
 Verwertung und Mitteilung ihres Inhalts nicht  
 gestattet, soweit nicht ausdruuecklich zugestanden.  
 Zuwiderhandlungen verpflichten zu Schadenersatz.

Bemerkung - Note Nicht ohne Kuehlmittel betreiben! Not for use without coolant-fluid! Tmax Klemmbolzen Revolver = 25 Nm	Technische Daten - technical data M1 / M2 = 20 / 60 Nm n1 / n2 = 6000 / 2000 1/min i (N1:N2) = 3:1 pmax = 70 bar	Benennung - Title <b>Radial Bohr und Fräskopf</b> <i>Radial drilling and milling head</i>	name Schmid	date 13.03.2007	Technische Aenderungen vorbehalten! Subject to technical modifications! Nr. <b>60.3025KRTNC65RLIK13</b> MNR: 129396 IDENT: D-EWS-009854 - Blatt - page 1 (1)
			EWS Weigele GmbH & Co. KG Maybachstr. 1 D-73066 Uhingen Tel. +49(0)7161/93040-100		