

Spannzange / collet ER40 DIN6499
 Spannbereich / clamping range: 3,0 - 26,0

Gewindebohrzange / tapping collet
 ET-1-40 M6-M16

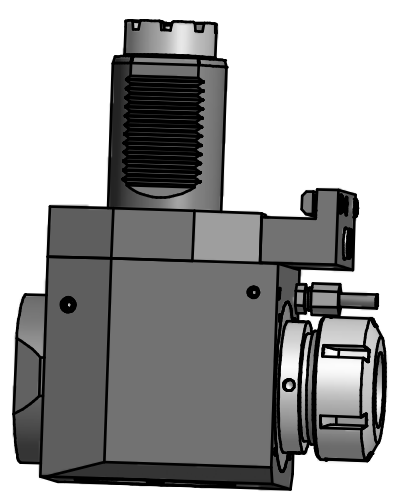
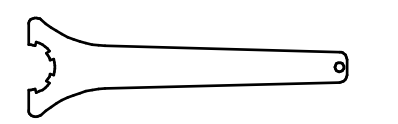

 Hakenschlüssel
 mit Zapfen
 Hook wrench
 with fixed pin
 DIN1810 B 58x62

 Spannzangenschlüssel
 Clamping wrench
 240

Copyright **EWS Tool Technologies**
 Weitergabe und Vervielfaeltigung dieser Unterlage,
 Verwertung und Mitteilung ihres Inhalts nicht
 gestattet, soweit nicht ausdrecklich zugestanden.
 Zuwiderhandlungen verpflichten zu Schadenersatz.

Bemerkung - Note 	Technische Daten - technical data M1 / M2 = 100 / 100 Nm n1 / n2 = 4000 / 4000 1/min i (N1:N2) = 1:1	Benennung - Title Radial Bohr und Fräskopf <i>Radial drilling and milling head</i>	<table border="1"> <tr> <th>name</th> <th>date</th> </tr> <tr> <td>Schmid</td> <td>09.03.2007</td> </tr> </table>	name	date	Schmid	09.03.2007	Technische Aenderungen vorbehalten! Subject to technical modifications! Nr. 60.5040HANKRGL MNR: 132458 IDENT: D-EWS-014039 - Blatt - page 2 of 2
name	date							
Schmid	09.03.2007							