

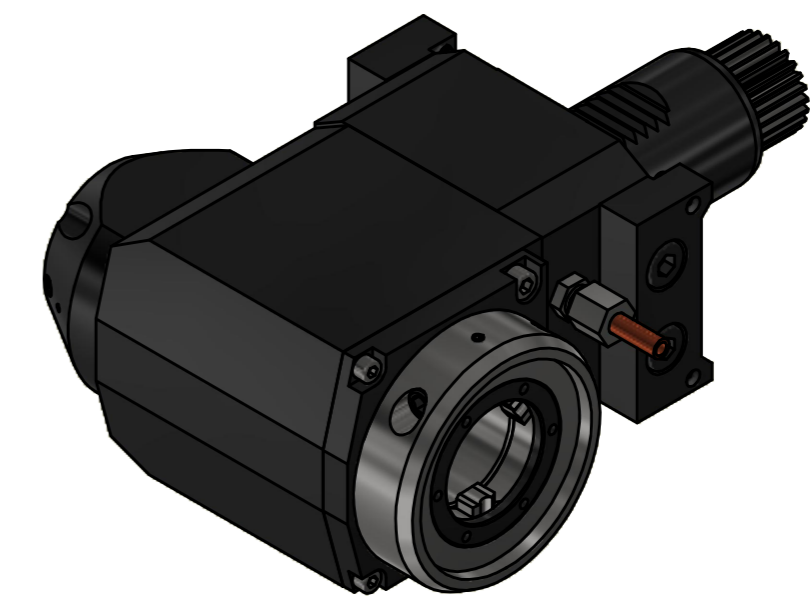

EWS.Varia

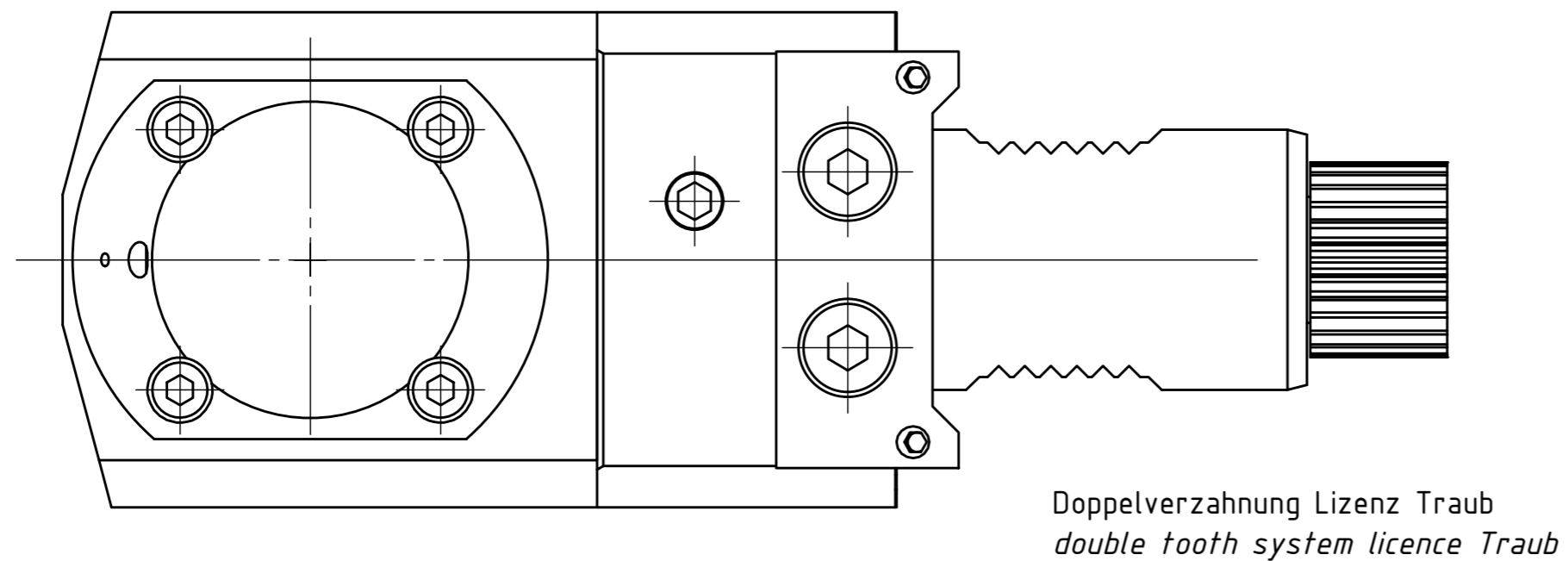

Tech
Details

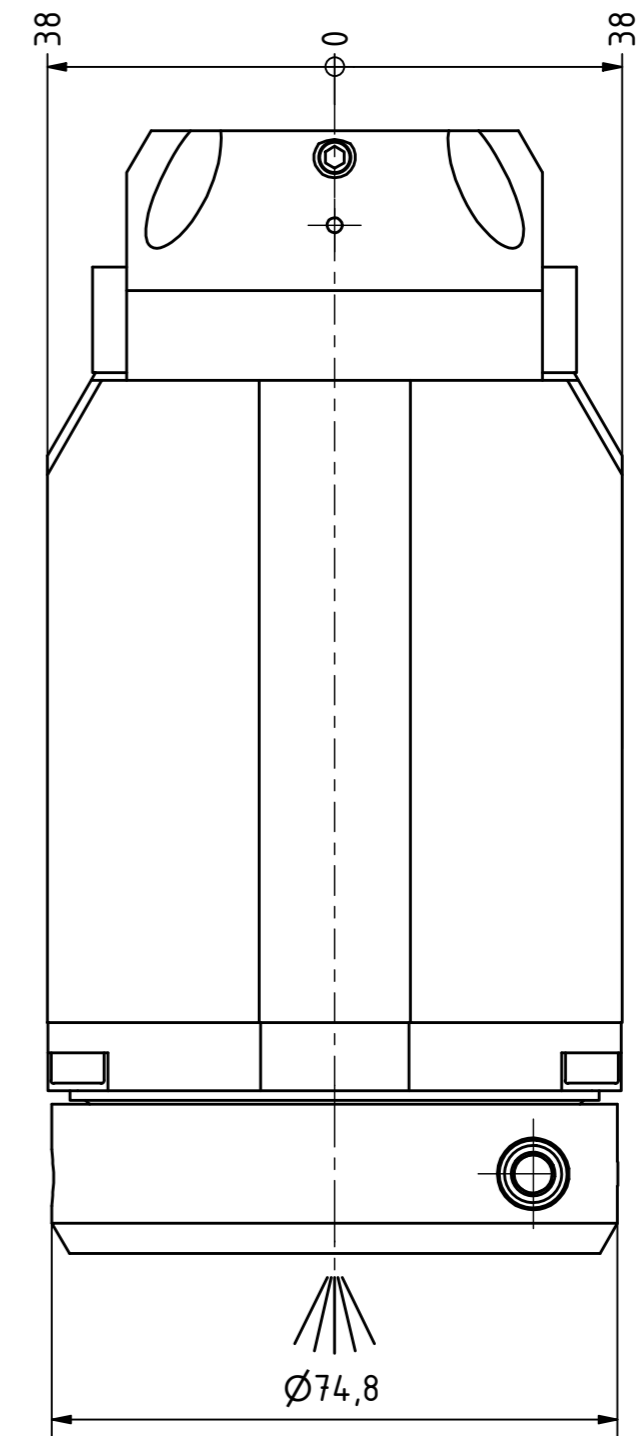
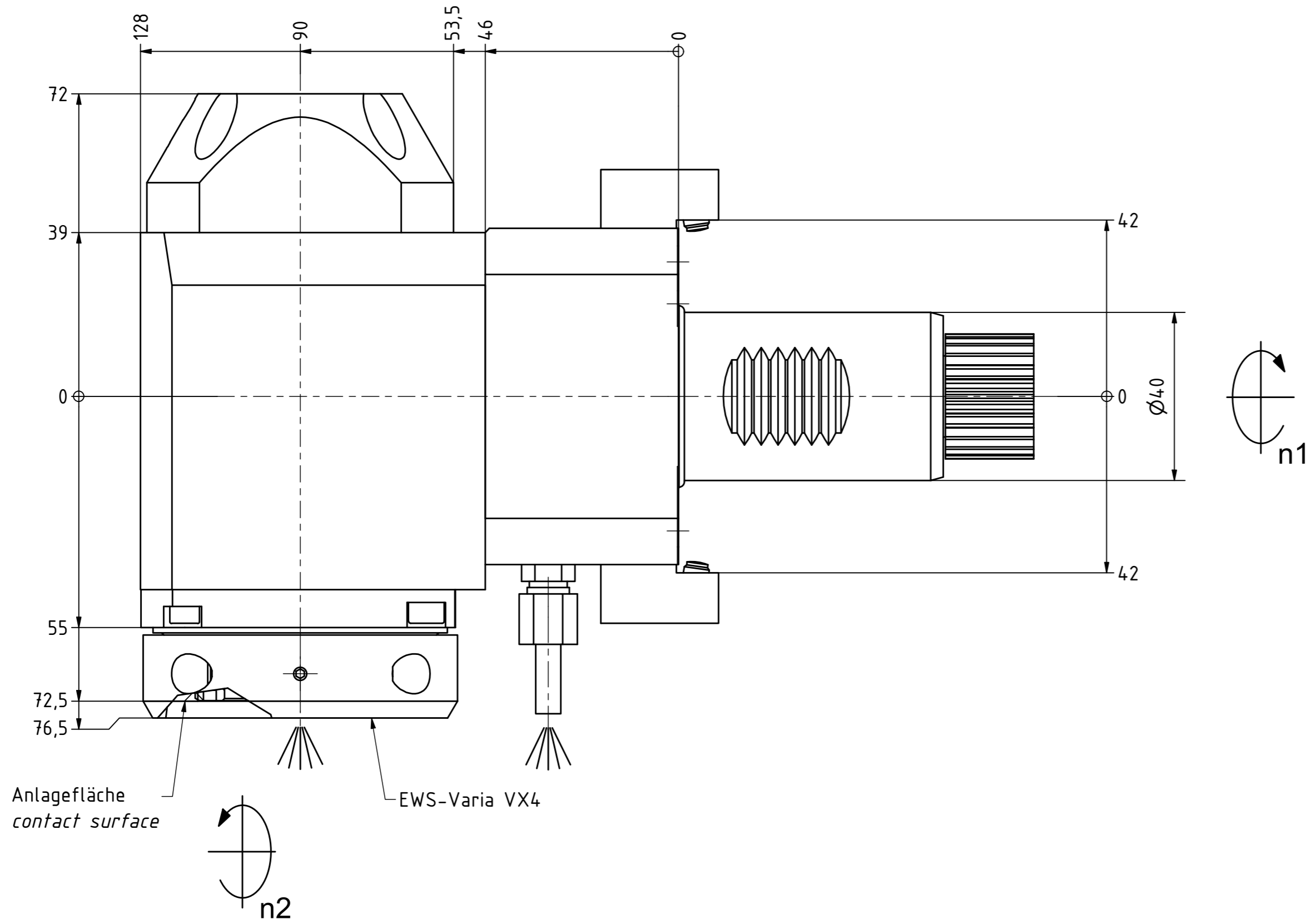

Copyright **EWS Tool Technologies**
Weitergabe und Vervielfältigung dieser Unterlage,
Verwertung und Mitteilung ihres Inhalts nicht
gestattet, soweit nicht ausdrücklich zugestanden.
Zuwerhandlungen verpflichten zu Schadenersatz.

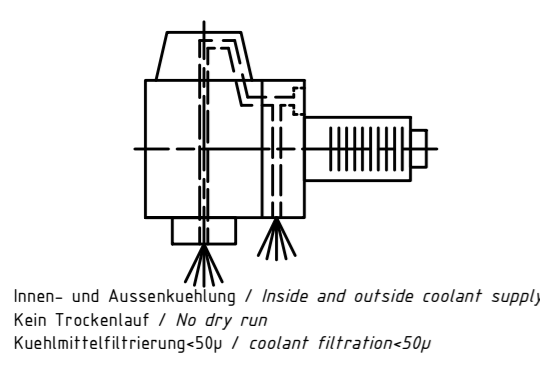

| | | | | |
|--|--|--|---|---|
| <p>Bemerkung - Note Nicht ohne Kuehlmittel betreiben! Not for use without coolant-fluid!</p> | <p>Technische Daten - technical data Weight = 7.236 [kg] Torque max. (M1/M2) = 50 / 50 [Nm] Speed max. (n1/n2) = 6000 / 6000 [1/min] Gear ratio (i)=n1:n2 = 1:1 Pressure (pmax) = 70 [bar]</p> | <p>Benennung - Title Radial Bohr und Fräskopf Radial drilling and milling head</p> | <p>EWS Tool Technologies EWS Weigle GmbH & Co. KG Maybachstr. 1 D-73066 Uhlingen www.ews-tools.de</p> <p>Technische Aenderungen vorbehalten! Subject to technical modifications! IDENT: DEWS233861</p> | <p>Nr. - No. 60.40VX4 TNX65RLIK</p> <p>REV: -/A MNR. 161908</p> |
|--|--|--|---|---|

