

Spannzange / *collet* ER40 DIN6499
 Spannungsbereich / *clamping range*: 3,0 - 26,0

Gewindebohrzange / *tapping collet*
 ET-1-40 M6-M16

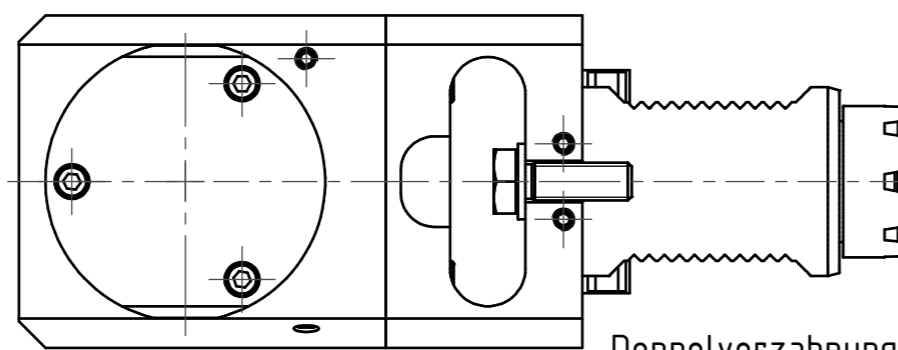

Doppelverzahnung Lizenz Traub
double tooth system licence Traub

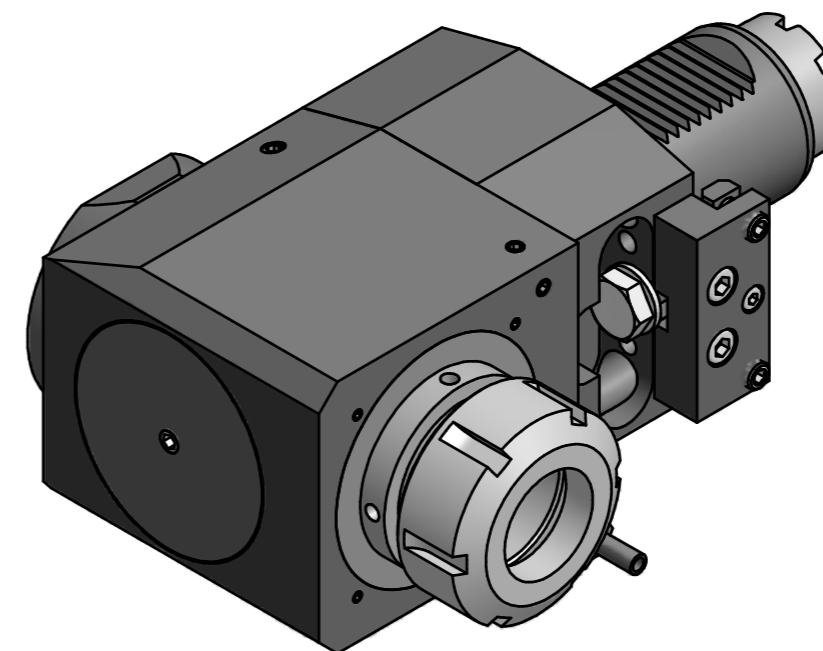
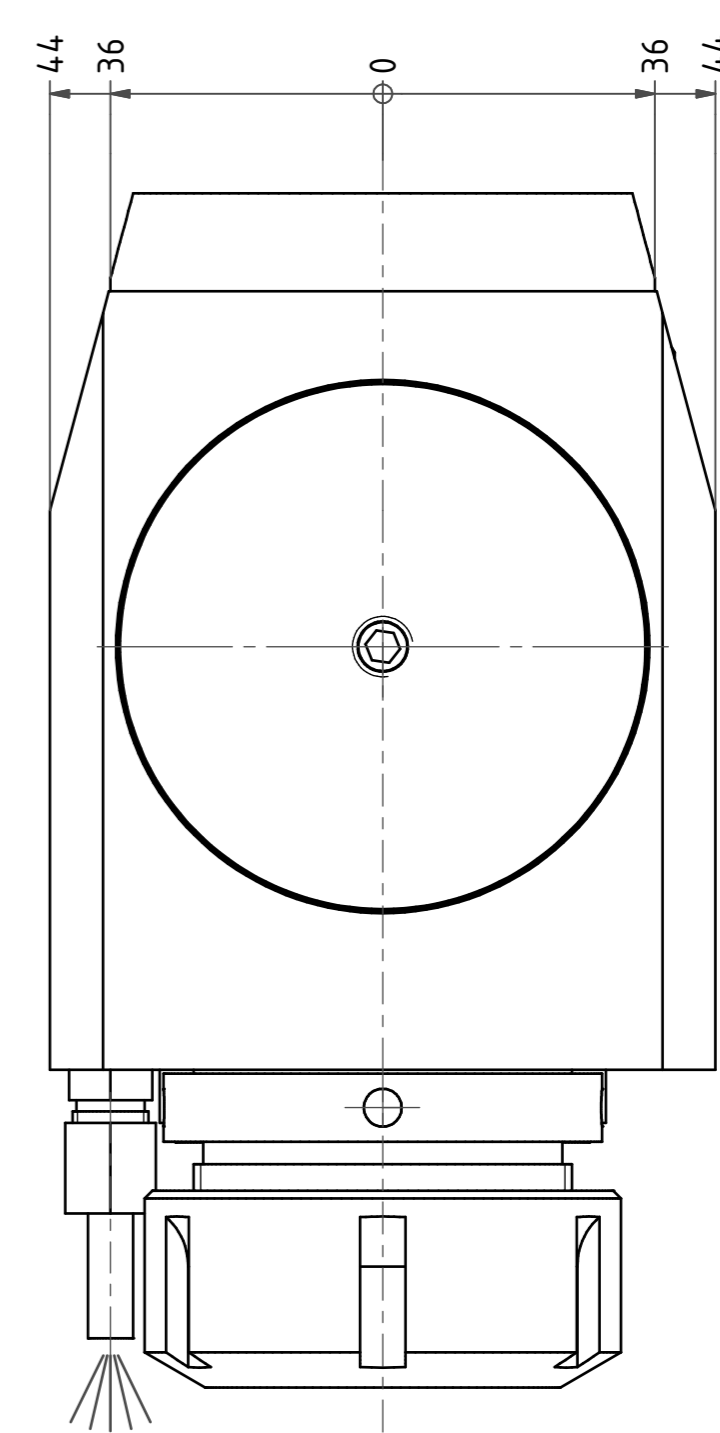

Hakenschlüssel
 mit Zapfen
*Hook wrench
 with fixed pin*
 DIN1810 B 58x62

Spannzangenschlüssel
Clamping wrench
 240

Copyright **EWS Tool Technologies**
 Weitergabe und Vervielfältigung dieser Unterlage,
 Verwertung und Mitteilung ihres Inhalts nicht
 gestattet, soweit nicht ausdrücklich zugestanden.
 Zuwiderhandlungen verpflichten zu Schadenersatz.

Bemerkung - <i>Note</i>	Technische Daten - <i>technical data</i>		Benennung - <i>Title</i> Radial Bohr und Fräskopf <i>Radial drilling and milling head</i>	name	date	Technische Änderungen vorbehalten! <i>Subject to technical modifications!</i>	
	M ₁ / M ₂ = 100 / 100 Nm n ₁ / n ₂ = 4 000 / 4 000 1/min i (N ₁ :N ₂) = 1:1	drawing		Schmid	27.02.2007		
						DIN A2	
				MNR: 133048		IDENT: D-EWS-006461 - Blatt - page 1 (1)	