

Spannzange / collet ER25 DIN6499
 Spannbereich / clamping range: 1,0 - 16,0
 Gewindebohrzange / tapping collet
 ET-1-25 M3-M10

 Spannzangenschlüssel
 Clamping wrench
 225

 Hakenschlüssel
 mit Nase
 Hook wrench with
 nose end
 DIN1810 A 58x62

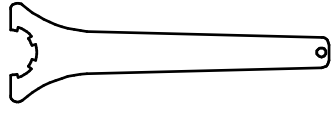
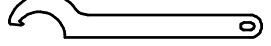
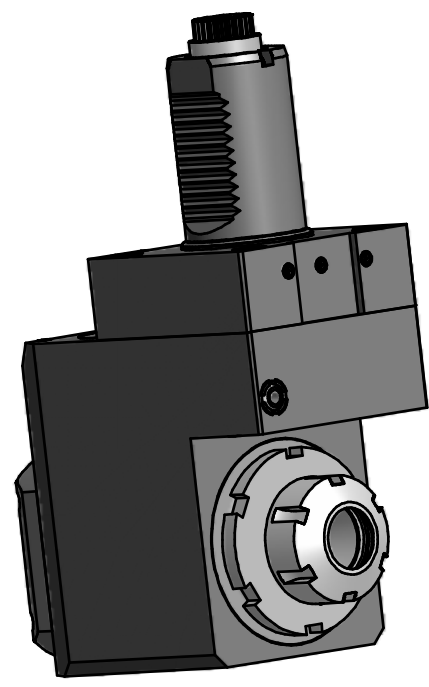

Copyright **EWS Tool Technologies**
 Weitergabe und Vervielfaeltigung dieser Unterlage,
 Verwertung und Mitteilung ihres Inhalts nicht
 gestattet, soweit nicht ausdrecklich zugestanden.
 Zuwiderhandlungen verpflichten zu Schadenersatz.

Bemerkung - Note	Technische Daten - technical data M1 / M2 = 50 / 25 Nm n1 / n2 = 6000 / 12000 1/min i (N1:N2) = 1:2	Benennung - Title Radial Bohr und Fräskopf. zurückges Radial drill. and mill. head offset	<table border="1"> <tr> <th>name</th> <th>date</th> </tr> <tr> <td>Kratschmann</td> <td>07.08.2007</td> </tr> </table>	name	date	Kratschmann	07.08.2007	Technische Aenderungen vorbehalten! Subject to technical modifications! Nr. 80.4025CTXR11 MNR: 131412 IDENT: D-EWS-049495 - Blatt - page 1 (1)
name	date							
Kratschmann	07.08.2007							

