

Doppelverzahnung Lizenz Traub
double tooth system licence Traub

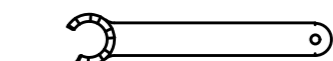

Spannzangenschlüssel für innenliegende Mutter
Clamping wrench for internal collet
232AX

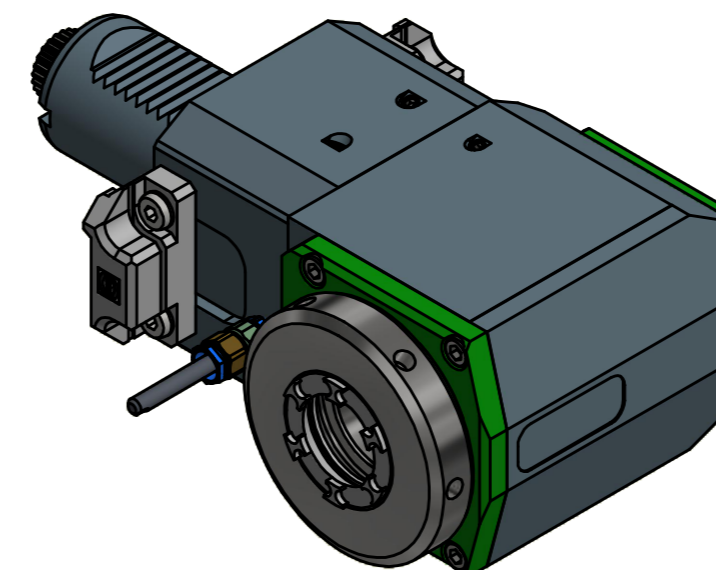
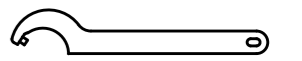

Hakenschlüssel mit Zapfen
Hook wrench with fixed pin
DIN1810 B 68x75

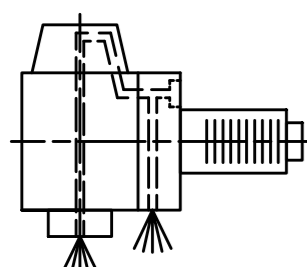

Innen- und Aussenkühlung / Inside and outside coolant supply
Kuehlmittelfiltrierung=50µ / coolant filtration=50µ

Copyright EWS Tool Technologies
Weitergabe und Vervielfaeltigung dieser Unterlage, Verwertung und Mitteilung ihres Inhalts nicht gestattet, soweit nicht ausdruecklich zugestanden. Zuwiderhandlungen verpflichten zu Schadenersatz.

Bemerkung - Note Für Trockenlauf geeignet! Use without coolant fluid allowed!	Technische Daten - technical data Weight = 6.839 [kg] Torque max. (M1/M2) = 63 / 63 [Nm] Speed max. (n1/n2) = 6000 / 6000 [1/min] Gear ratio (i)=n1:n2 = 1:1 Pressure (pmax) = 70 [bar]	Benennung - Title Radial Bohr und Fräskopf Radial drilling and milling head	<table border="1"> <tr> <td data-bbox="2226 1915 2463 1974"> EWS <small>EWS Weigle GmbH & Co. KG Maybachstr. 1 D-73066 Ulm/ingen www.ews-tool.de</small> </td> <td data-bbox="2463 1915 2671 1974"> Technische Aenderungen vorbehalten! Subject to technical modifications! IDENT: DEWS136920 </td> <td data-bbox="2671 1915 2908 1974"> REV: -/C MNR. </td> </tr> <tr> <td data-bbox="2226 1974 2463 2043"> Nr. - No. 60.4032CTXRLIKDTFIM </td> <td data-bbox="2463 1974 2671 2043"> 161739 </td> <td data-bbox="2671 1974 2908 2043"> QR </td> </tr> </table>	EWS <small>EWS Weigle GmbH & Co. KG Maybachstr. 1 D-73066 Ulm/ingen www.ews-tool.de</small>	Technische Aenderungen vorbehalten! Subject to technical modifications! IDENT: DEWS136920	 REV: -/C MNR.	Nr. - No. 60.4032CTXRLIKDTFIM	161739	QR
EWS <small>EWS Weigle GmbH & Co. KG Maybachstr. 1 D-73066 Ulm/ingen www.ews-tool.de</small>	Technische Aenderungen vorbehalten! Subject to technical modifications! IDENT: DEWS136920	 REV: -/C MNR.							
Nr. - No. 60.4032CTXRLIKDTFIM	161739	QR							