

Spannzange / collet ER25 DIN6499  
 Spannbereich / clamping range: 1,0 - 16,0

Gewindebohrzange / tapping collet  
 ET-1-25 M3-M10

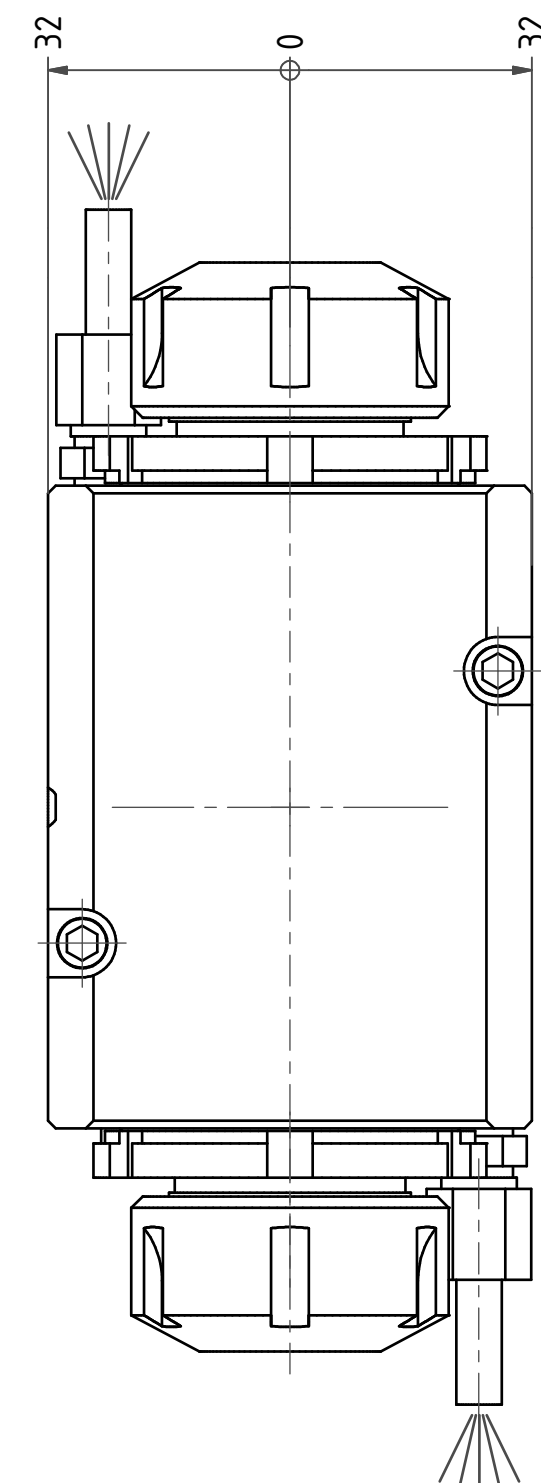

max. 74  
 min. 70,5

42,5

0

42,5

min. 70,5  
 max. 74

Ø42

131

100

57

0

Ø30

35

32

0

32

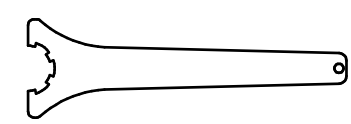

Spannzangenschlüssel  
 Clamping wrench  
 225

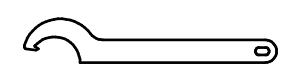

Hakenschlüssel  
 mit Nase  
 Hook wrench with  
 nose end  
 DIN1810 A 52x55

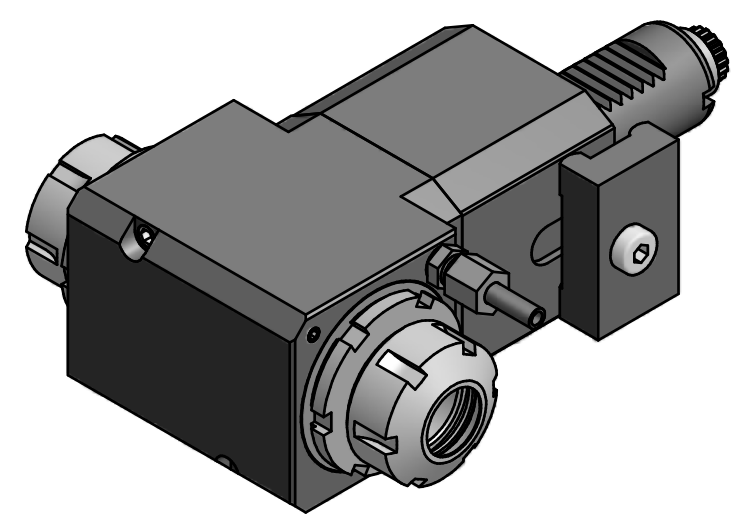

Copyright **EWS Tool Technologies**  
 Weitergabe und Vervielfaeltigung dieser Unterlage,  
 Verwertung und Mitteilung ihres Inhalts nicht  
 gestattet, soweit nicht ausdruücklich zugestanden.  
 Zuwiderhandlungen verpflichten zu Schadenersatz.

Bemerkung - Note

Technische Daten - technical data

Weight	= 4.778 [kg]
Torque max. (M1/M2)	= 25 / 25 each Sp. [Nm]
Speed max. (n1/n2)	= 8000 / 8000 [1/min]
Gear ratio (i)=n1:n2	= 1:1

Benennung - Title

**Radial Bohr und Fräskopf**  
*Radial drilling and milling head*

**EWS**  
 Tool Technologies

EWS Weigele GmbH & Co. KG  
 Maybachstr. 1  
 D-73066 Uhingen  
 www.ews-tools.de

Nr. - No.  
**60.3025LDCTXOT02**

Technische Aenderungen vorbehalten!  
 Subject to technical modifications!

IDENT: D-EWS-003829

REV: C/-

MNR.  
**128705**

