

Spannzange / collet ER40 DIN6499
Spannbereich / clamping range: 3,0 - 26,0

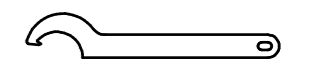

Hakenschlüssel
mit Nase
Hook wrench with
nose end
DIN1810 A 95x100

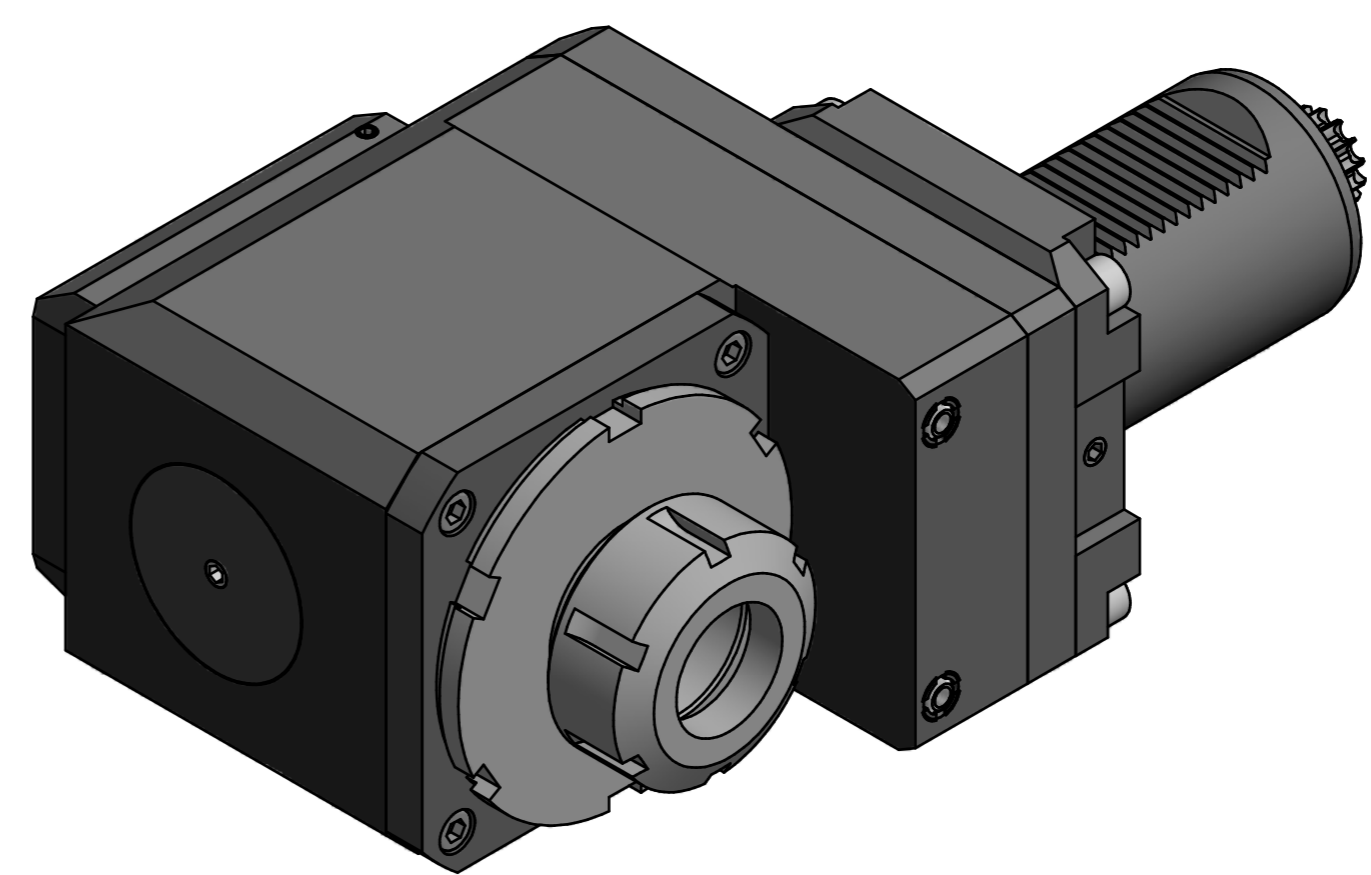

Spannzangenschlüssel
Clamping wrench

240

Copyright **EWS Tool Technologies**
Weitergabe und Vervielfältigung dieser Unterlage,
Verwertung und Mitteilung ihres Inhalts nicht
gestattet, soweit nicht ausdrücklich zugestanden.
Zuwerhandlungen verpflichten zu Schadenersatz.

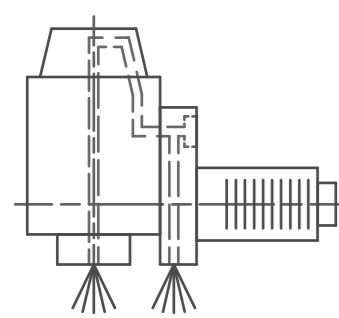

Innen- und Aussenkuehlung / Inside and outside coolant supply
Kein Trockenlauf / No dry run
Kuehlmittelfiltrierung 50μ / coolant filtration 50μ

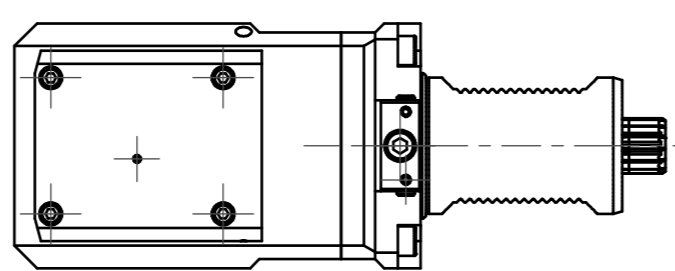

Doppelverzahnung Lizenz Traub
double tooth system licence Traub

Bezeichnung - Note	Technische Daten - technical data
Nicht ohne Kuehlmittel betreiben! Not for use without coolant-fluid!	Weight = 18.753 [kg]
mit Kegelrollenlager with taper roller bearing(s)	Torque max. (M1/M2) = 53 / 160 [Nm]
	Speed max. (n1/n2) = 3000 / 1000 [1/min]
	Gear ratio (i)=n1:n2 = 3:1
	Pressure (pmax) = 70 [bar]

Benennung - Title
Radial Bohr und Fräskopf. zurückges
Radial drill. and mill. head offset

 EWS Weigle GmbH & Co. KG D-73066 Ulm/Ingolstadt www.ews-tools.de	Technische Aenderungen vorbehalten! Subject to technical modifications! IDENT: D-EWS-123993	 REV: -/- MNR.
	Nr. - No. 80.6040KR5482RLIK13	

