

Innen- und Aussenkuehlung / Inside and outside coolant supply
 Kein Trockenlauf / No dry run
 Kuehmittelfiltrierung >50µ / coolant filtration >50µ

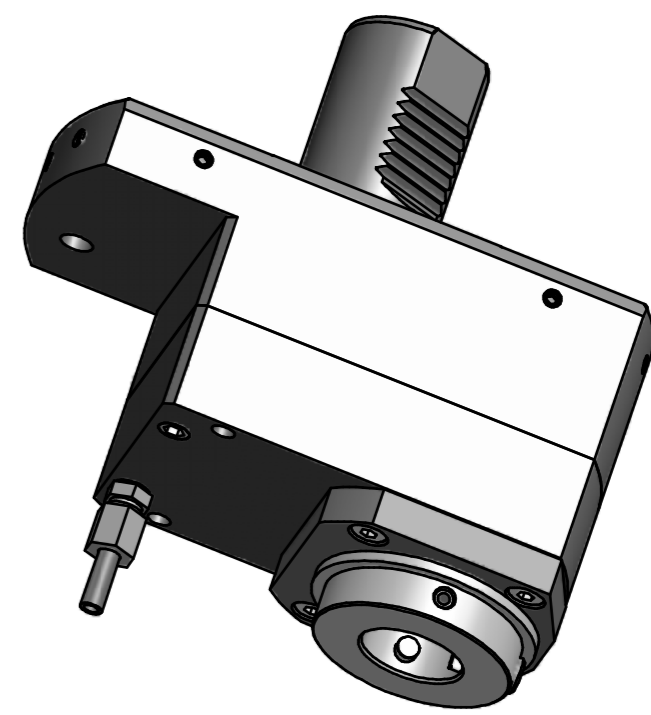

Copyright **EWS Tool Technologies**
 Weitergabe und Vervielfaeltigung dieser Unterlage,
 Verwertung und Mitteilung ihres Inhalts nicht
 gestattet, soweit nicht ausdrecklich zugestanden.
 Zuwiderhandlungen verpflichten zu Schadenersatz.

Bemerkung - Note Nicht ohne Kuehmittel betreiben! Not for use without coolant-fluid!	Technische Daten - Technical data M1 / M2 = 50 / 50 Nm n1 / n2 = 6000 / 6000 1/min i (N1:N2) = 1:1 Pmax = 70 bar	Benennung - Title Axial Bohr u. Fräskopf achsversetzt Ax. drill. and mill. head offset	name date 15.03.2007	Technische Aenderungen vorbehalten! Subject to technical modifications! Nr. 50.40V3SQT10RIK File: 50.40V3SQT10IK_OUT.idw	 DIN A2
			drawing		

