

Spannzange / collet ER40 DIN6499  
Spannbereich / clamping range: 3,0 - 26,0

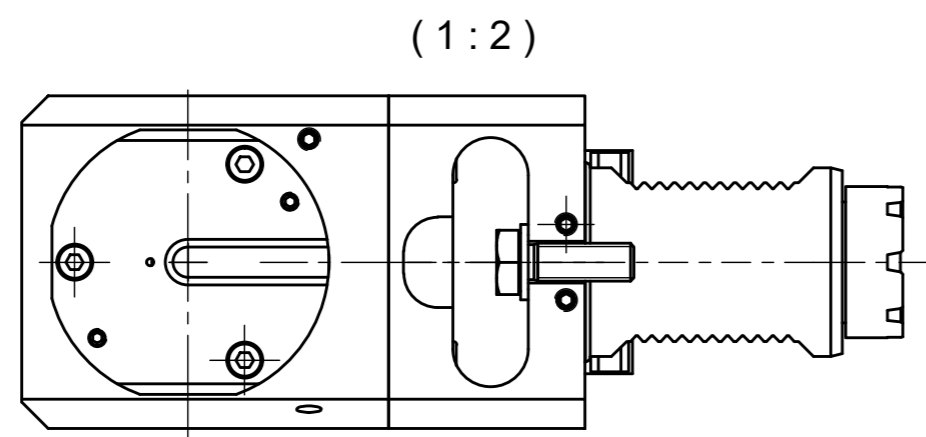

Doppelverzahnung Lizenz Traub  
double tooth system licence Traub

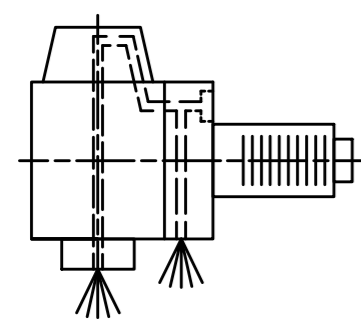

Innen- und Aussenkuehlung / Inside and outside coolant supply  
Kuehlmittelfiltrierung-50µ / coolant filtration-50µ

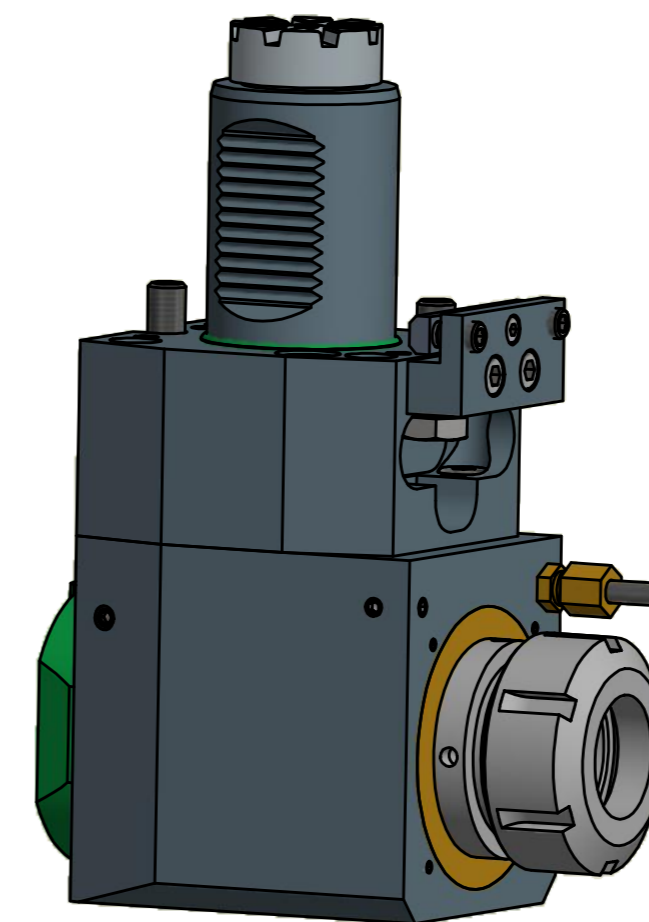

  
Hakenschlüssel  
mit Zapfen  
Hook wrench  
with fixed pin  
DIN1810 B 58x62

  
Spannzangenschlüssel  
Clamping wrench  
240

Copyright **EWS Tool Technologies**  
Weitergabe und Vervielfaeltigung dieser Unterlage,  
Verwertung und Mitteilung ihres Inhalts nicht  
gestattet, soweit nicht ausdrecklich zugestanden.  
Zuwoerhandlungen verpflichten zu Schadenersatz.

Bemerkung - Note  
Für Trockenlauf geeignet!  
Use without coolant fluid allowed!

Technische Daten - technical data  
Weight = 9.636 [kg]  
Torque max. (M1/M2) = 100 / 100 [Nm]  
Speed max. (n1/n2) = 4000 / 4000 [1/min]  
Gear ratio (i)=n1:n2 = 1:1  
Pressure (pmax) = 70 [bar]

Benennung - Title  
Radial Bohr und Fräskopf  
Radial drilling and milling head

**EWS** Tool Technologies  
EWS Weigle GmbH & Co. KG  
Maybachstr. 1  
D-73066 Uhlingen  
www.ews-tool.de  
Technische Aenderungen vorbehalten!  
Subject to technical modifications!  
IDENT: D-EWS-006453  
REV: -/-  
MNR.  
60.5040TOEMRLIKDX105  
128495

QR