

Fraeserwelle austauschbar
Spindel removable

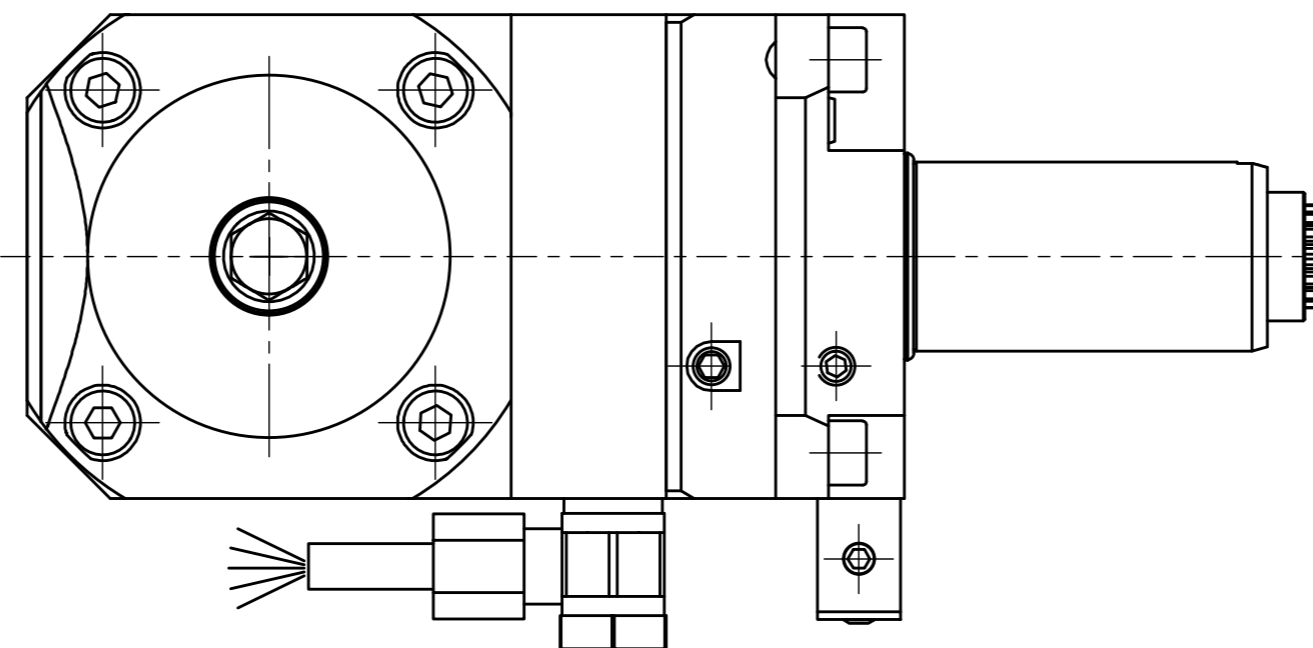
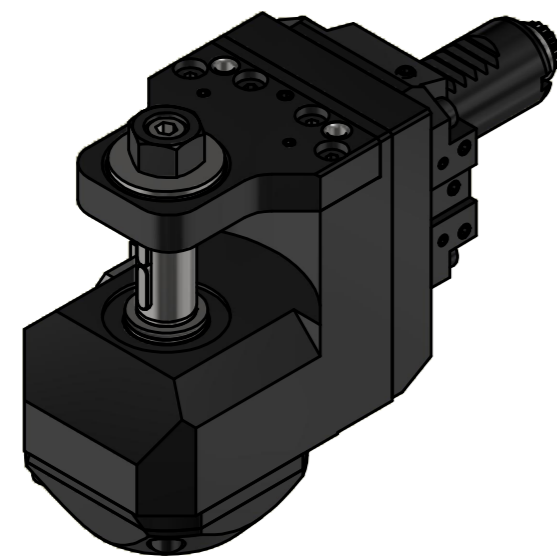
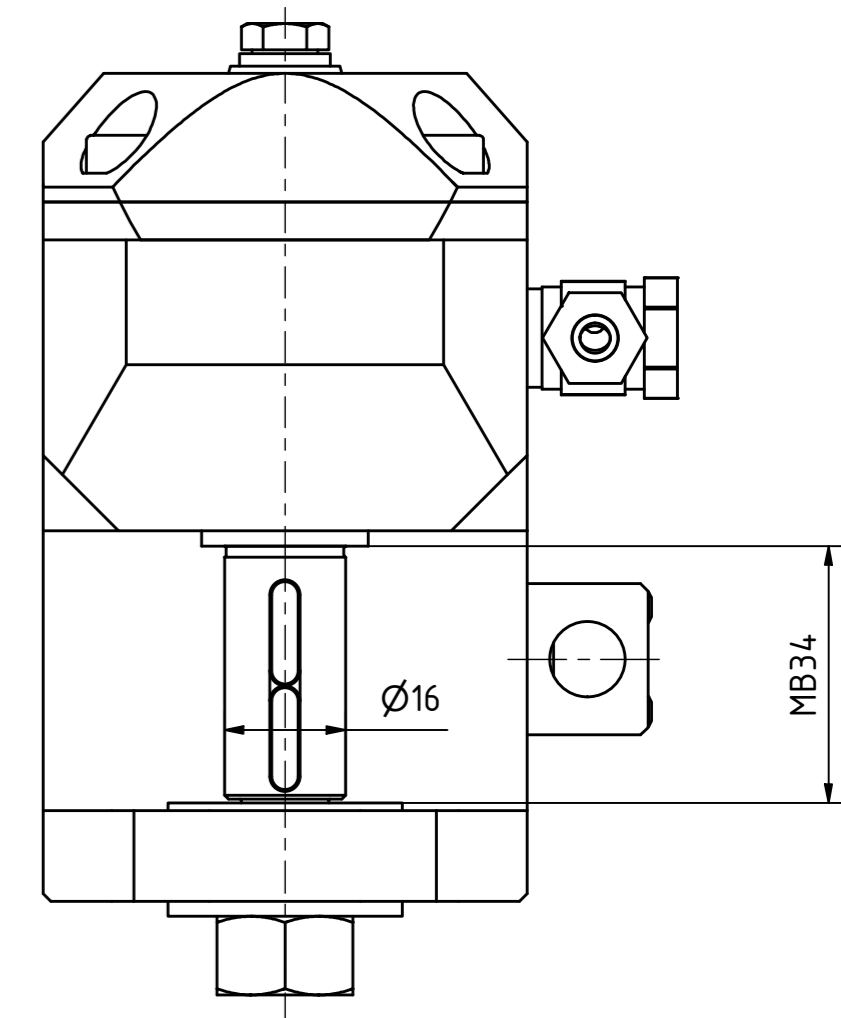

Copyright **EWS Tool Technologies**
Weitergabe und Vervielfältigung dieser Unterlage,
Verwertung und Mitteilung ihres Inhalts nicht
gestattet, soweit nicht ausdrücklich zugestanden.
Zuwerhandlungen verpflichten zu Schadenersatz.

Bemerkung - Note	Technische Daten - technical data Weight = 3.700 [kg] Torque max. (M1/M2) = 20 / 60 [Nm] Speed max. (n1/n2) = 6000 / 2000 [1/min] Gear ratio (i)=n1:n2 = 3:1	Benennung - Title Scheibenfräserkopf Radial saw milling head	 EWS Weigle GmbH & Co. KG Maybachstr. 1 D-73066 Uhlingen www.ews-tools.de Technische Änderungen vorbehalten! Subject to technical modifications! IDENT: D-EWS-003272 Nr. - No. 64.2516548013-S02	 REV: -/A MNR. 129183	
------------------	--	--	---	--	---