

Spannzange / collet ER25 DIN6499  
 Spannbereich / clamping range: 1,0 - 16,0

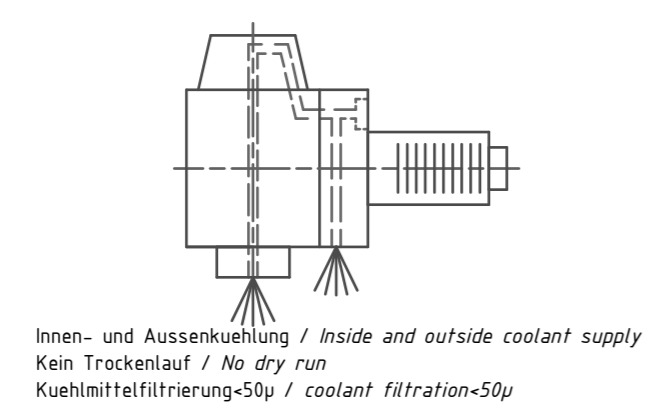
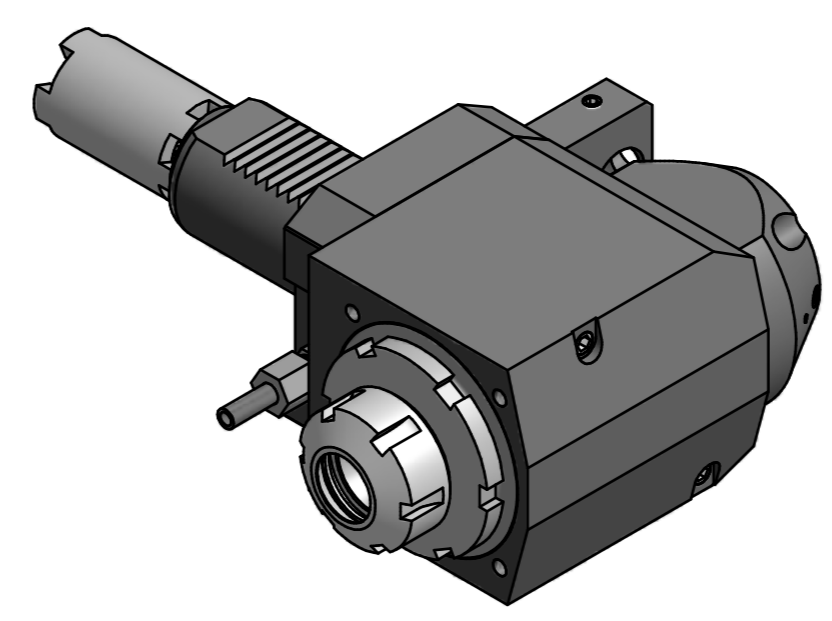
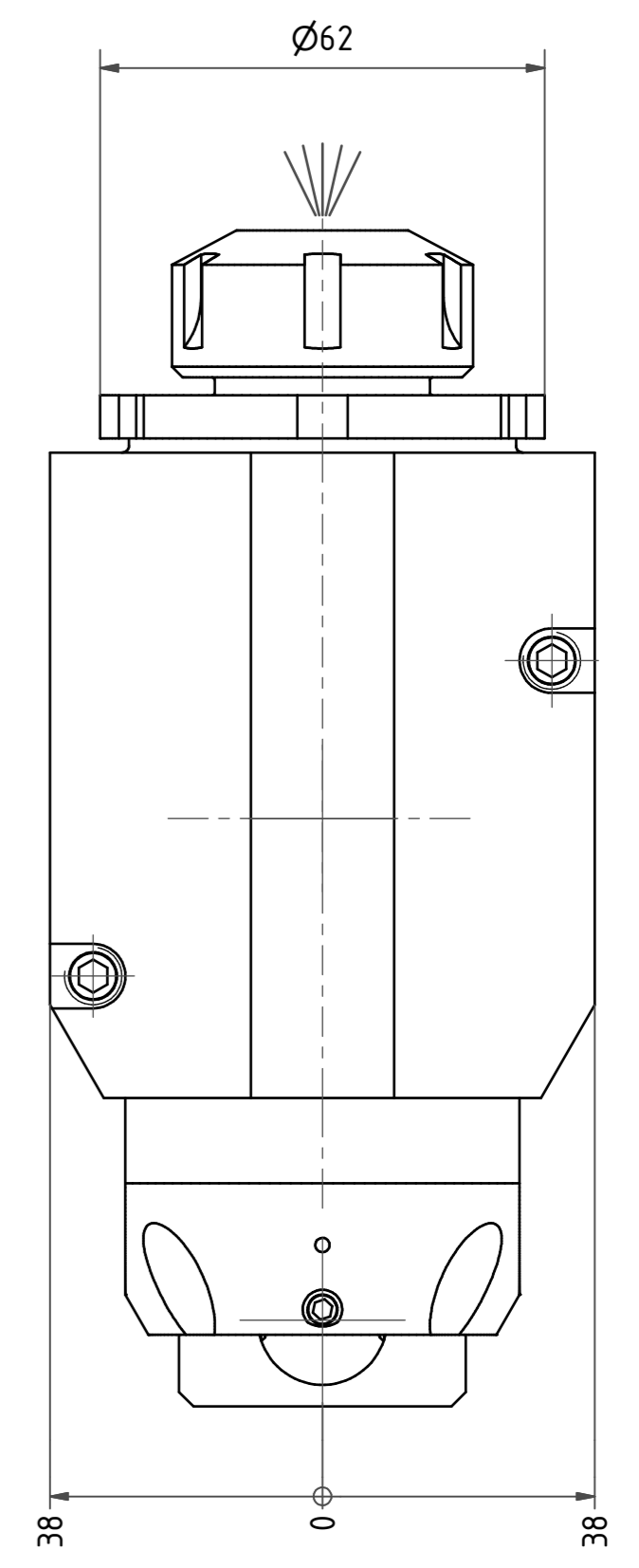

Innen- und Aussenkuehlung / Inside and outside coolant supply  
 Kein Trockenlauf / No dry run  
 Kuehlmittelfiltrierung-50µ / coolant filtration-50µ

Bemerkung - Note  
 Nicht ohne Kuehlmittel betreiben!  
 Not for use without coolant-fluid!

Technische Daten - technical data	
Weight	= 5,912 [kg]
Torque max. (M1/M2)	= 50 / 25 [Nm]
Speed max. (n1/n2)	= 6000 / 12000 [1/min]
Gear ratio (i)=n1:n2	= 1:2
Pressure (pmax)	= 70 [bar]

Benennung - Title  
**Radial Bohr und Fräskopf**  
*Radial drilling and milling head*

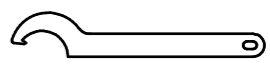
 Hakenschlüssel mit Nase  
 Hook wrench with nose end  
 DIN1810 A 58x62

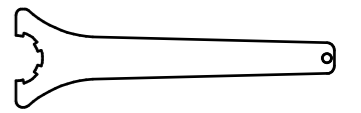
 Spannzangenschlüssel  
 Clamping wrench  
 225

Copyright **EWS Tool Technologies**  
 Weitergabe und Vervielfaeltigung dieser Unterlage,  
 Verwertung und Mitteilung ihres Inhalts nicht  
 gestattet, soweit nicht ausdrecklich zugestanden.  
 Zuwiderhandlungen verpflichten zu Schadenersatz.

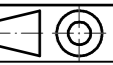
<b>EWS</b> Tool Technologies	EWS Weigele GmbH & Co. KG Maybachstr. 1 D-73066 Uhlringen www.ews-tools.de	Technische Aenderungen vorbehalten! Subject to technical modifications!	
	Nr. - No. <b>60.4025HAASSL40LIK1</b>	IDENT: D-EWS-196960	REV: -/- MNR. <b>162360</b>

