

Spannzange / collet ER25 DIN6499  
Spannbereich / clamping range: 1,0 - 16,0

Doppelverzahnung Lizenz Traub  
double tooth system licence Traub

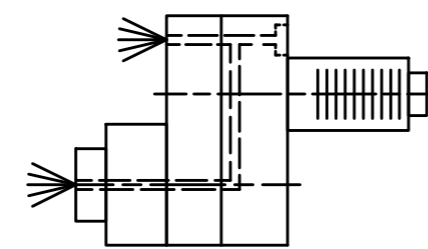
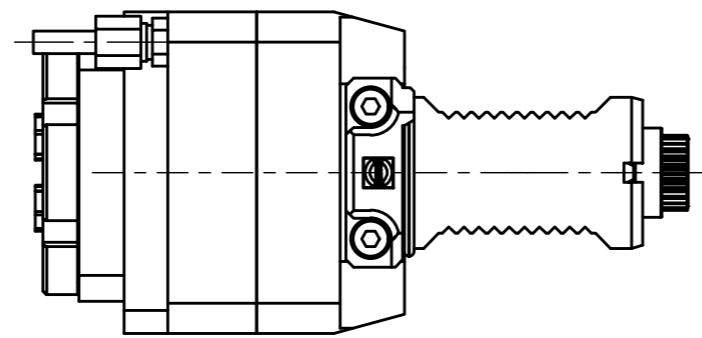

Innen- und Aussenkuehlung / Inside and outside coolant supply  
Kein Trockenlauf / No dry run  
Kuehlmittelfiltrierung <math>< 50\mu</math> / coolant filtration <math>< 50\mu</math>

Spannzangenschlüssel für innenliegende Mutter  
Clamping wrench for internal collet  
225AX

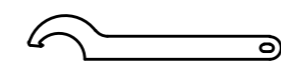

Hakenschlüssel mit Nase  
Hook wrench with nose end  
DIN1810 A 68x75

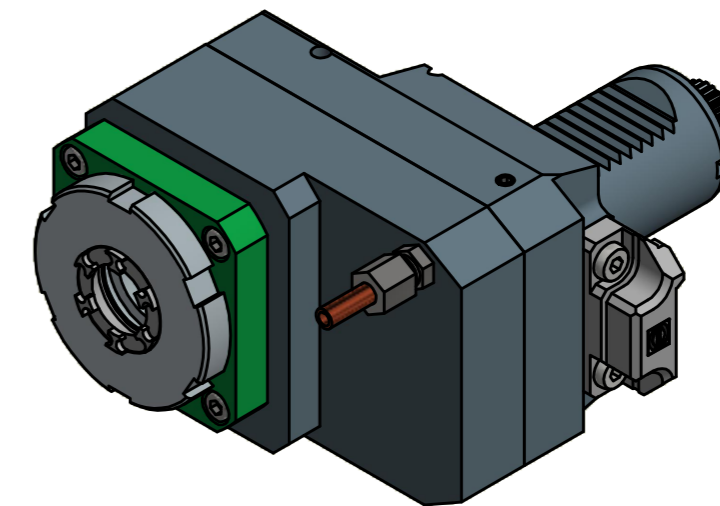

Copyright EWS Tool Technologies  
Weitergabe und Vervielfaeltigung dieser Unterlage, Verwertung und Mitteilung ihres Inhalts nicht gestattet, soweit nicht ausdrecklich zugestanden. Zuwiderhandlungen verpflichten zu Schadenersatz.

Bemerkung - Note Nicht ohne Kuehlmittel betreiben! Not for use without coolant-fluid!	Technische Daten - technical data Weight = 5.957 [kg] Torque max. (M1/M2) = 45 / 15 [Nm] Speed max. (n1/n2) = 5000 / 15000 [1/min] Gear ratio (i) = n1:n2 = 1:3 Pressure (pmax) = 70 [bar]
---	---

Benennung - Title  
**Axial Bohr u. Fräskopf achsversetzt**  
**Ax. drill. and mill. head offset**

<b>EWS</b> Tool Technologies <small>EWS Weigle GmbH &amp; Co. KG          Maybachstr. 1          D-73066 Uhlingen          www.ews-tool.de</small>	Technische Aenderungen vorbehalten! Subject to technical modifications! IDENT: D-EWS-123673	 REV: -/- MNR. <b>162327</b>
Nr. - No. <b>50.4025CTXRLIK113TFLIM</b>		

