

Spannzange / collet ER40 DIN6499
 Spannbereich / clamping range: 3,0 - 26,0

Gewindebohrzange / tapping collet
 ET-1-40 M6-M16

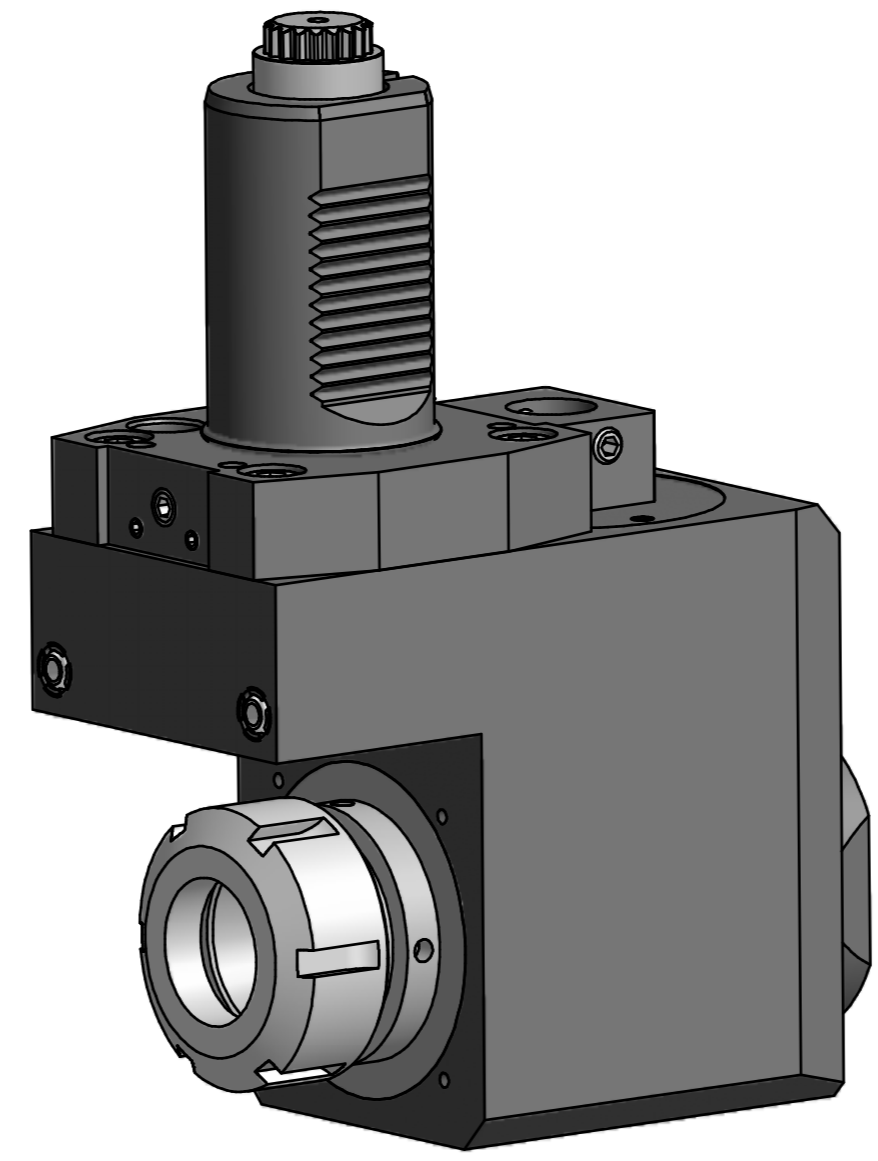
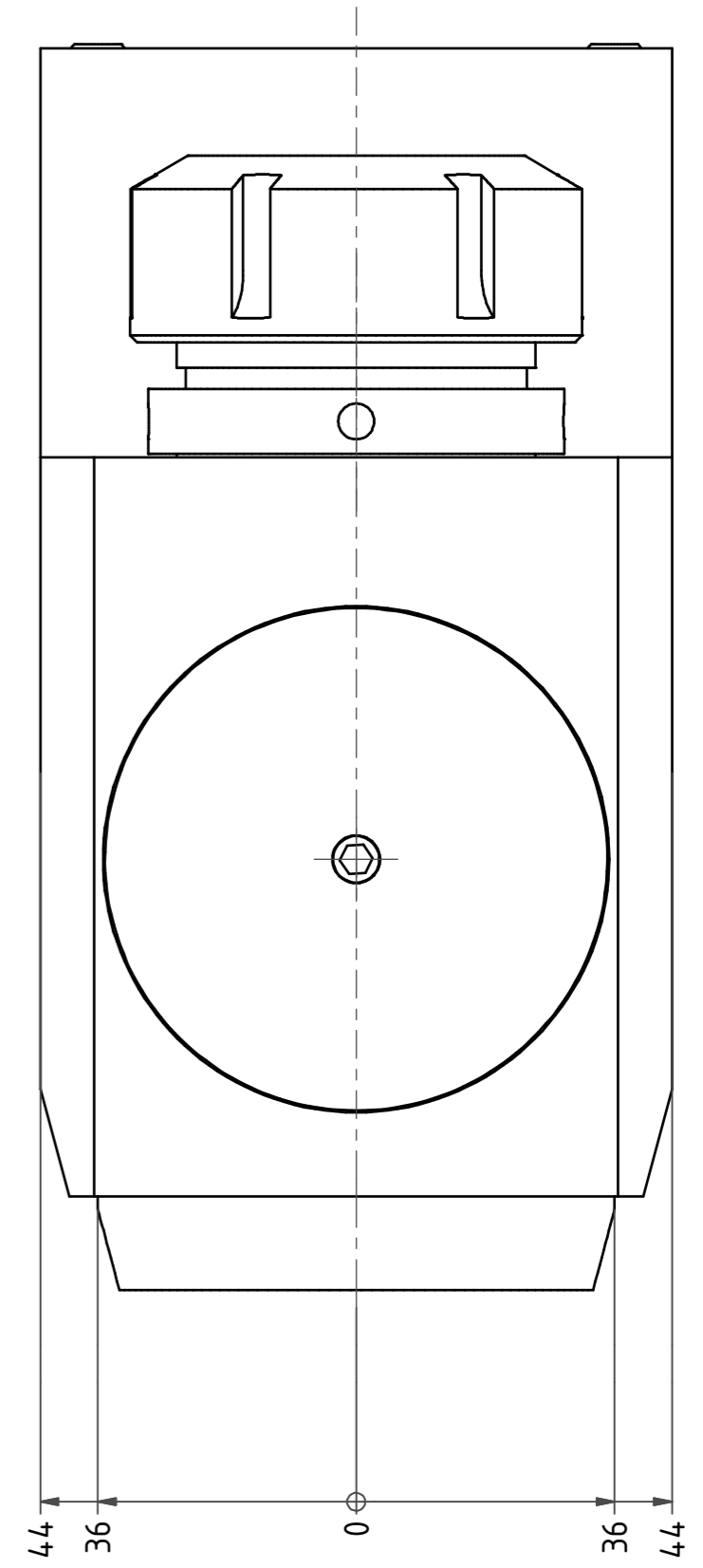
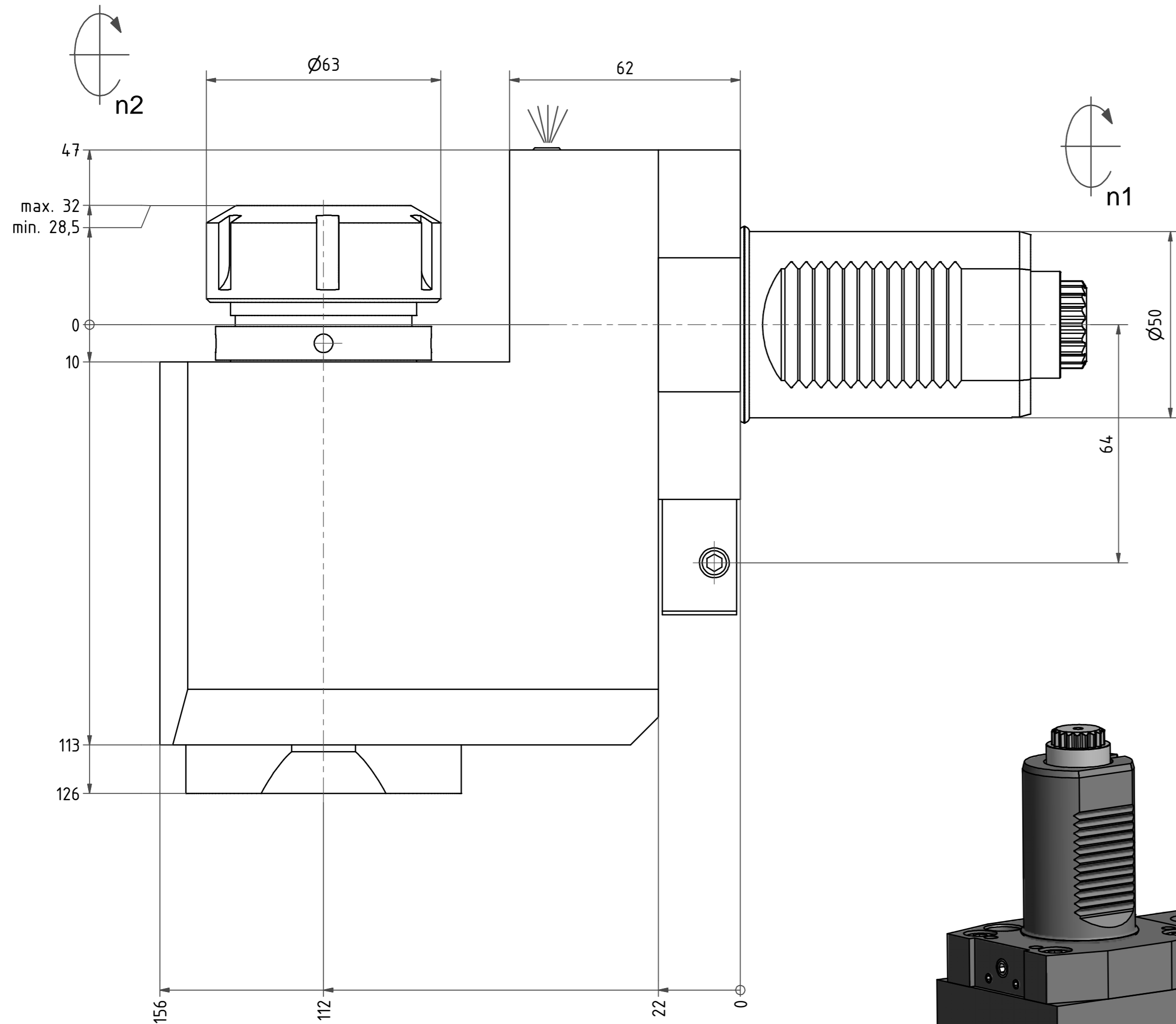
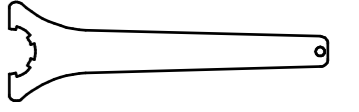

 Hakenschlüssel
 mit Zapfen
 Hook wrench
 with fixed pin
 DIN1810 B 58x62

 Spannzangenschlüssel
 Clamping wrench
 240

Copyright **EWS Tool Technologies**
 Weitergabe und Vervielfältigung dieser Unterlage,
 Verwertung und Mitteilung ihres Inhalts nicht
 gestattet, soweit nicht ausdrücklich zugestanden.
 Zuwiderhandlungen verpflichten zu Schadenersatz.

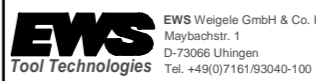
Bemerkung - Note	Technische Daten - Technical data M₁ / M₂ = 100 / 100 Nm n₁ / n₂ = 4000 / 4000 1/min i (N₁:N₂) = 1:1	Benennung - Title Radial Bohr und Fräskopf. zurückges Radial drill. and mill. head offset	name	date	Technische Änderungen vorbehalten! Subject to technical modifications!
			drawing	12.03.2007	
			 EWS Werkzeug GmbH & Co. KG <small>Maybachstr. 1 D-73066 Ulm/Gen Tool Technologies Tel. +49(0)7161/93040-100</small>		Nr. 80.50405480L
			MNR: 128431		IDENT: D-EWS-005588 -
			Blatt - page 1 (1)		DIN A2