

Spannzange / collet ER25 DIN6499
 Spannbereich / clamping range: 1,0 - 16,0

Gewindebohrzange / tapping collet
 ET-1-25 M3-M10

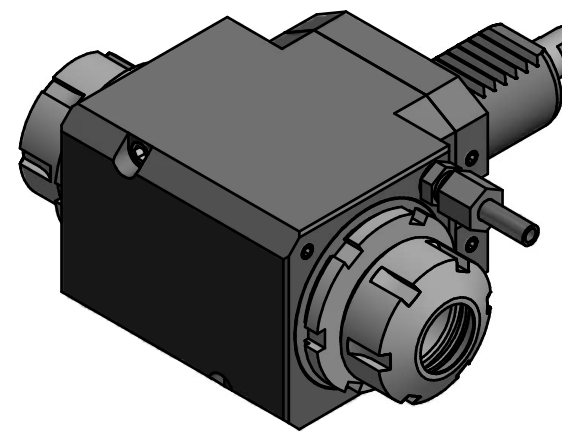

Copyright **EWS Tool Technologies**
 Weitergabe und Vervielfaeltigung dieser Unterlage,
 Verwertung und Mitteilung ihres Inhalts nicht
 gestattet, soweit nicht ausdruuecklich zugestanden.
 Zuwiderhandlungen verpflichten zu Schadenersatz.

Bemerkung - Note	

Technische Daten - technical data	
Weight	= 3.449 [kg]
Torque max. (M1/M2)	= 25 / 25 each Sp. [Nm]
Speed max. (n1/n2)	= 8000 / 8000 [1/min]
Gear ratio (i)=n1:n2	= 1:1

Benennung - Title	
Radial Bohr und Fräskopf	
<i>Radial drilling and milling head</i>	

 <small>EWS Weigele GmbH & Co. KG Maybachstr. 1 D-73066 Uhingen www.ews-tools.de</small>	<small>Technische Aenderungen vorbehalten!</small> <small>Subject to technical modifications!</small>
	<small>IDENT: D-EWS-000550</small>
<small>Nr. - No.</small> 60.3025D1809	<small>MNR.</small> 128405

	<small>REV: B/-</small>

