

Spannzange / collet ER32 DIN6499
 Spannungsbereich / clamping range: 2,0 - 20,0

Gewindebohrzange / tapping collet
 ET-1-32 M5-M12

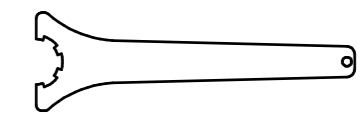

Spannzangenschlüssel
 Clamping wrench
 232

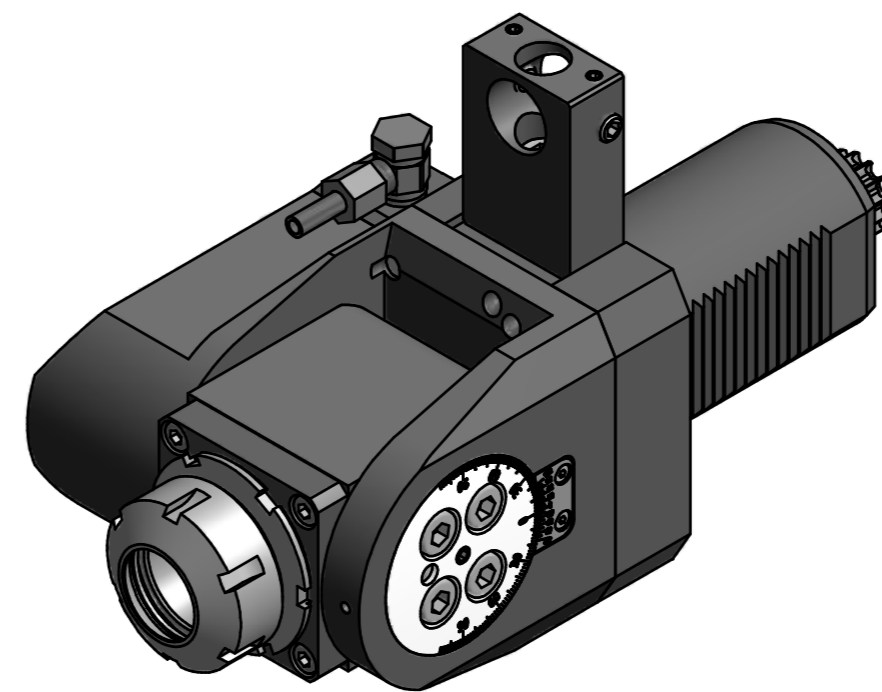
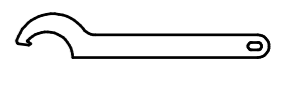

Hakenschlüssel
 mit Nase
 Hook wrench with
 nose end
 DIN1810 A 58x62

Copyright **EWS Tool Technologies**
 Weitergabe und Vervielfältigung dieser Unterlage,
 Verwertung und Mitteilung ihres Inhalts nicht
 gestattet, soweit nicht ausdrücklich zugestanden.
 Zuwiderhandlungen verpflichten zu Schadenersatz.

Bemerkung - Note	Technische Daten - technical data		Benennung - Title	name date Technische Änderungen vorbehalten! Subject to technical modifications! Nr. 63.60325482 MNR: 131195 IDENT: D-EWS-185387 - Blatt - page 1 (1)
	M ₁ / M ₂ = 50 / 50 Nm n ₁ / n ₂ = 4.000 / 4.000 1/min i (N ₁ :N ₂) = 1:1			
Schwenkkopf Swivel head			EWS Weigete GmbH & Co. KG Maybachstr. 1 D-72096 Ulm/lingen Tel. +49(0)7161/93040-100	DIN A2