

Spannzange / collet ER40 DIN6499
Spannbereich / clamping range: 3,0 - 26,0

Gewindebohrzange / tapping collet
ET-1-40 M6-M16

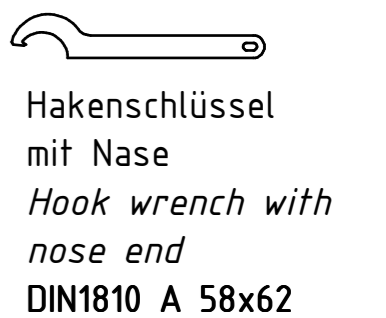
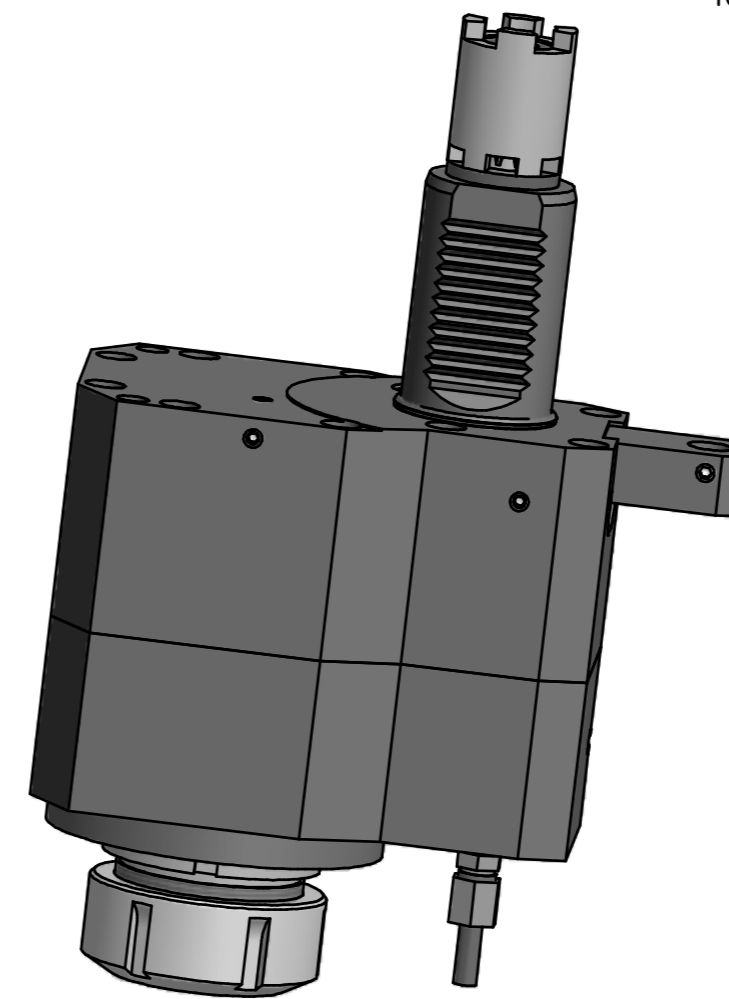
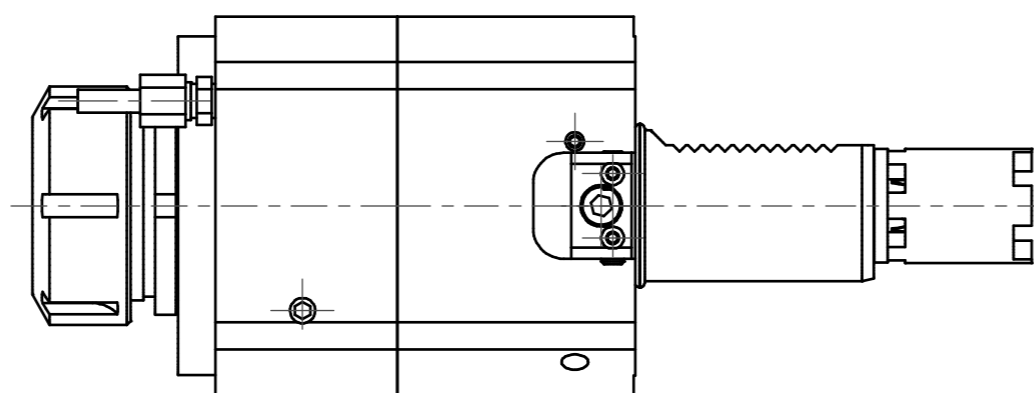

Copyright **EWS Tool Technologies**
Weitergabe und Vervielfältigung dieser Unterlage,
Verwertung und Mitteilung ihres Inhalts nicht
gestattet, soweit nicht ausdrücklich zugestanden.
Zuwendungen verpflichten zu Schadenersatz.

Bemerkung - Note	Technische Daten - Technical data M ₁ / M ₂ = 40 / 120 Nm n ₁ / n ₂ = 6000 / 2000 1/min i (N ₁ :N ₂) = 2,895:1	Benennung - Title Axial Bohr u. Fräskopf achsversetzt Ax. drill. and mill. head offset	name	date	Technische Änderungen vorbehalten! Subject to technical modifications!	DIN A2
			drawing	20.03.2007		
			EWS Weigete GmbH & Co. KG Maybachstr. 1 D-73066 Ulmingen Tel. +49(0)7161/93040-10		File: 50.4040HAASSL20I3_OUT.idw	Blatt - page 1 (1)