

Doppelverzahnung Lizenz Traub
double tooth system licence Traub

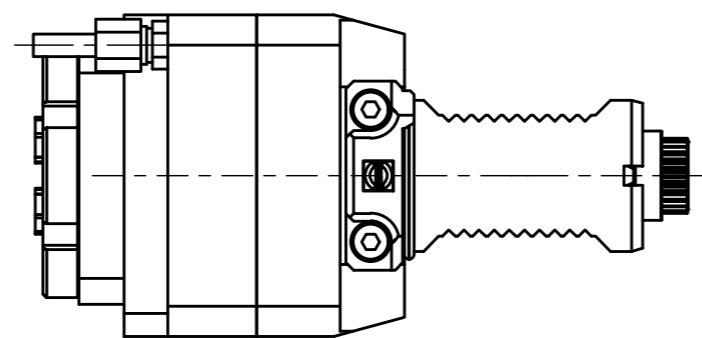

Spannzange / collet ER25 DIN6499
Spannbereich / clamping range: 1,0 - 16,0

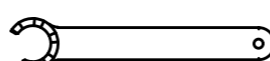

Gewindebohrzange / tapping collet
ET-1-25 M3-M12

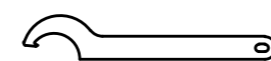
Spannzangenschlüssel für
innenliegende Mutter
Clamping wrench for
internal collet
225AX

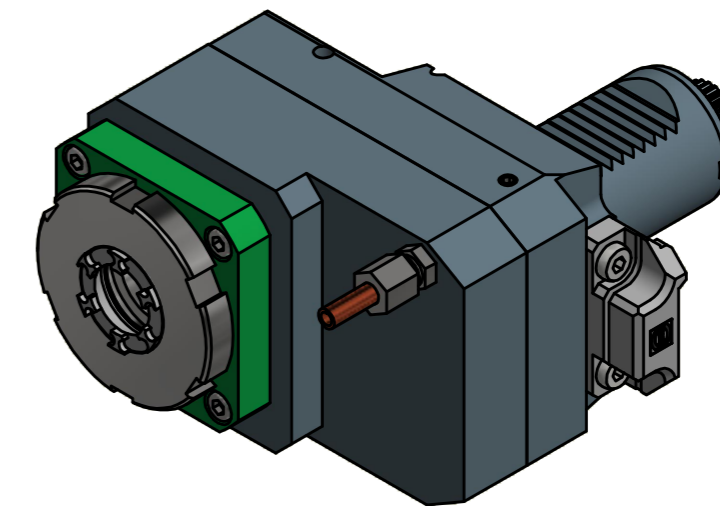
Hakenschlüssel
mit Nase
Hook wrench with
nose end
DIN1810 A 68x75

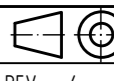

Copyright **EWS Tool Technologies**
Weitergabe und Vervielfältigung dieser Unterlage,
Verwertung und Mitteilung ihres Inhalts nicht
gestattet, soweit nicht ausdrücklich zugestanden.
Zu widerhandlungen verpflichten zu Schadenersatz.

Bemerkung - Note	Technische Daten - technical data Weight = 5.958 [kg] Torque max. (M1/M2) = 45 / 15 [Nm] Speed max. (n1/n2) = 5000 / 15000 [1/min] Gear ratio (i)=n1:n2 = 1:3	Benennung - Title Axial Bohr u. Fräskopf achsversetzt Ax. drill. and mill. head offset	 EWS Weigle GmbH & Co. KG Maybachstr. 1 D-73066 Ulm/ingen www.ews-tool.de	Technische Änderungen vorbehalten! Subject to technical modifications! IDENT: D-EWS-124658 MNR.	 REV: -/- 159697	
------------------	---	--	---	--	---	---