

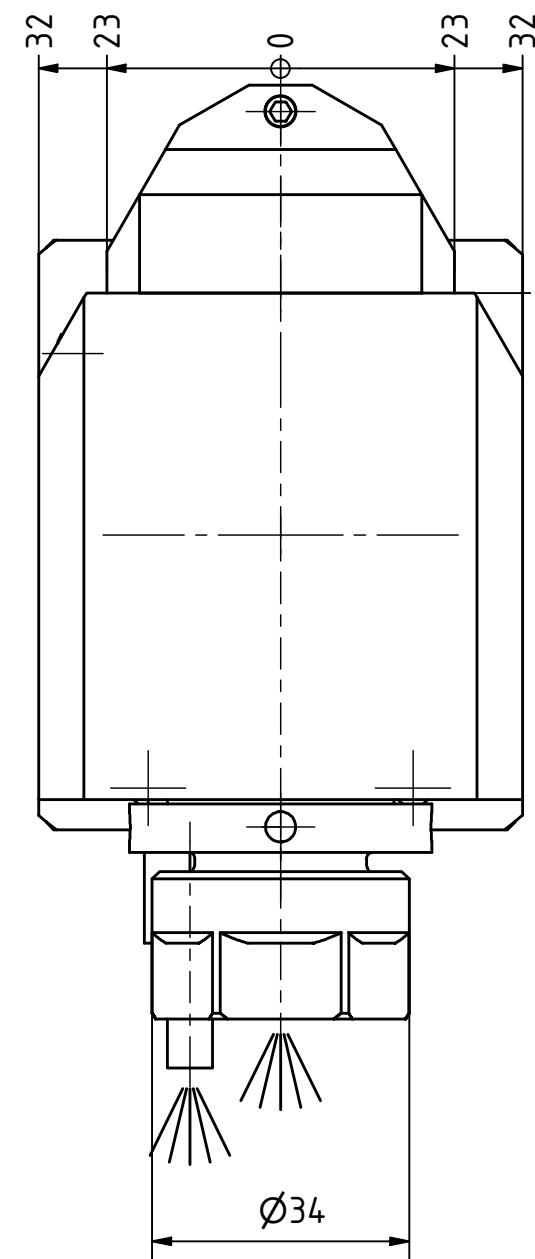

Highspeed  
Tech Details

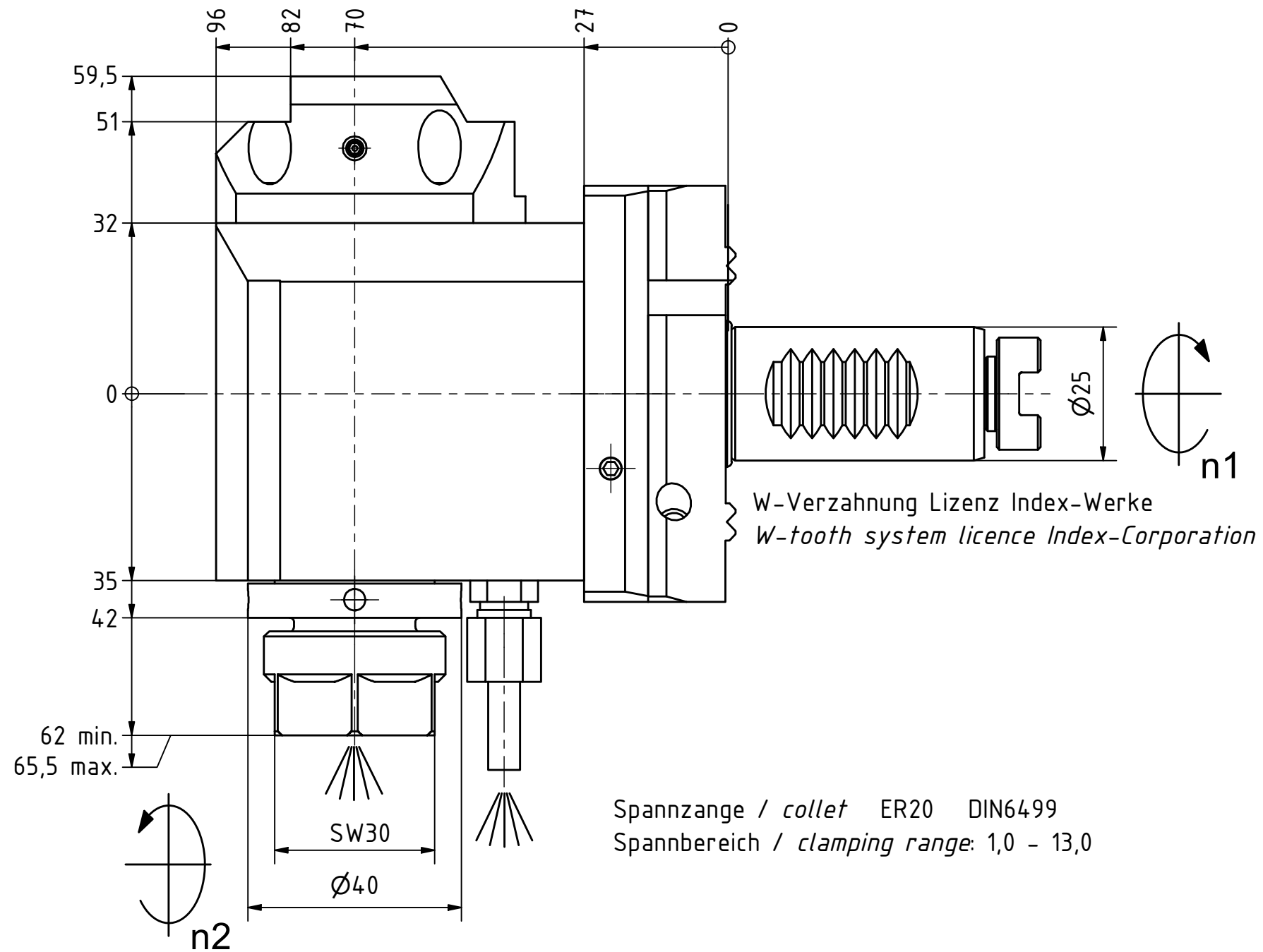

Spannzange / collet ER20 DIN6499  
Spannbereich / clamping range: 1,0 - 13,0

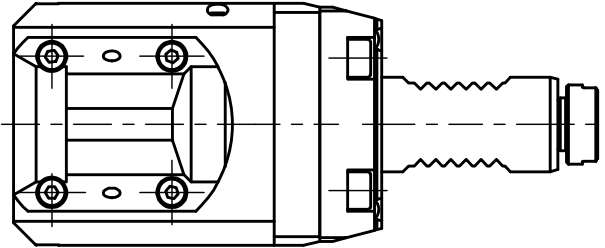
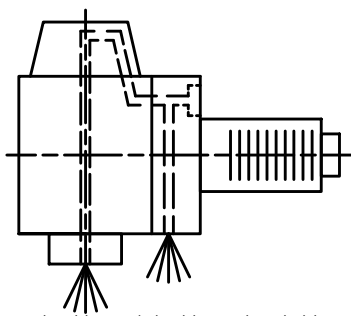

Doppelverzahnung Lizenz Traub  
double tooth system licence Traub

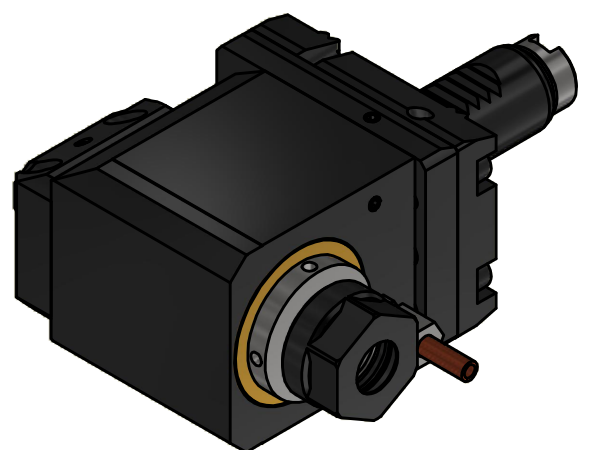

Hakenschlüssel  
mit Zapfen  
Hook wrench  
with fixed pin  
DIN1810 B 40x42

Copyright **EWS Tool Technologies**  
Weitergabe und Vervielfaeltigung dieser Unterlage,  
Verwertung und Mitteilung ihres Inhalts nicht  
gestattet, soweit nicht ausdrecklich zugestanden.  
Zuwiderhandlungen verpflichten zu Schadenersatz.

Bemerkung - Note  
Nicht ohne Kuehlmittel betreiben!  
Not for use without coolant-fluid!

Technische Daten - technical data	
Weight	= 3.419 [kg]
Torque max. (M1/M2)	= 24 / 12 [Nm]
Speed max. (n1/n2)	= 6000 / 12000 [1/min]
Gear ratio (i)=n1:n2	= 1:2
Pressure (pmax)	= 70 [bar]

Benennung - Title  
**Radial Bohr und Fräskopf**  
**Radial drilling and milling head**

**EWS** Tool Technologies  
EWS Weigele GmbH & Co. KG  
Maybachstr. 1  
D-73066 UHINGEN  
www.ews-tools.de

Nr. - No.  
**60.2520G200RLIK11W**

Technische Aenderungen vorbehalten! Subject to technical modifications!	
IDENT: DEWS238495	REV: -/A
MNR.	128986

