

Spannzange / collet ER25 DIN6499
 Spannbereich / clamping range: 1,0 - 16,0

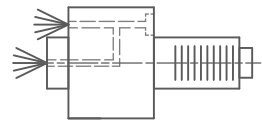

Innen- und Aussenkuehlung / Inside and outside coolant supply
 Kein Trockenlauf / No dry run
 Kuehlmittelfiltrierung-50 μ / coolant filtration-50 μ

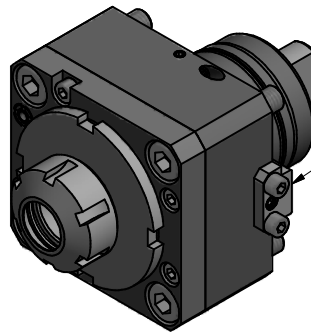

Ausrichtklotz ist über ein Exzenter einstellbar.
 The block is adjustable via eccentric.

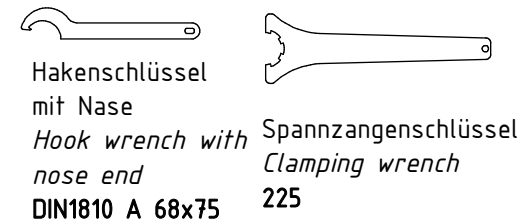

Hakenschlüssel mit Nase
 Hook wrench with nose end
 DIN1810 A 68x75

Spannzangenschlüssel 225
 Clamping wrench 225

Copyright **EWS Tool Technologies**
 Weitergabe und Vervielfältigung dieser Unterlage, Verwertung und Mitteilung ihres Inhalts nicht gestattet, soweit nicht ausdrücklich zugestanden. Zuwiderhandlungen verpflichten zu Schadenersatz.

<p>Bemerkung - Note Nicht ohne Kuehlmittel betreiben! Not for use without coolant-fluid!</p>	<p>Technische Daten - technical data Weight = 3.253 [kg] Torque max. (M1/M2) = 50 / 50 [Nm] Speed max. (n1/n2) = 6000 / 6000 [1/min] Gear ratio (i)=n1:n2 = 1:1 Pressure (pmax) = 25 [bar]</p>	<p>Benennung - Title Axial Bohr und Fräskopf Axial drilling and milling head</p>	<p>EWS Tool Technologies <small>EWS Weigelt GmbH & Co. KG Maybachstr. 1 D-73066 Uhingen www.ews-tools.de</small></p> <p>Nr. - No. 40.5525NEX906IK</p>	<p>Technische Änderungen vorbehalten! Subject to technical modifications! IDENT: DEWS016207 MNR. REV: -/A 159694</p>	
--	---	--	--	---	---