

min. 115  
max. 122

$\varnothing 78$

n2

Spannzange / collet ER50 DIN6499  
Spannbereich / clamping range: 6,0 - 34,0

 Hakenschlüssel  
mit Nase  
Hook wrench with  
nose end  
DIN1810 A 80x90

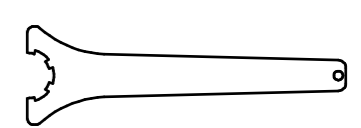
 Spannzangenschlüssel  
Clamping wrench  
250

Copyright **EWS Tool Technologies**  
Weitergabe und Vervielfältigung dieser Unterlage,  
Verwertung und Mitteilung ihres Inhalts nicht  
gestattet, soweit nicht ausdrücklich zugestanden.  
Zuwendungen verpflichten zu Schadenersatz.

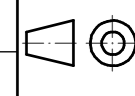
Bemerkung - Note	Technische Daten - Technical data		Benennung - Title	name date Technische Änderungen vorbehalten! Subject to technical modifications!	 DIN A2
	M <sub>1</sub> / M <sub>2</sub> = 160 / 160 Nm n <sub>1</sub> / n <sub>2</sub> = 3000 / 3000 1/min i (N <sub>1</sub> :N <sub>2</sub> ) = 1:1	<b>Radial Bohr und Fräskopf</b> <i>Radial drilling and milling head</i>			