

second pin must be pulled

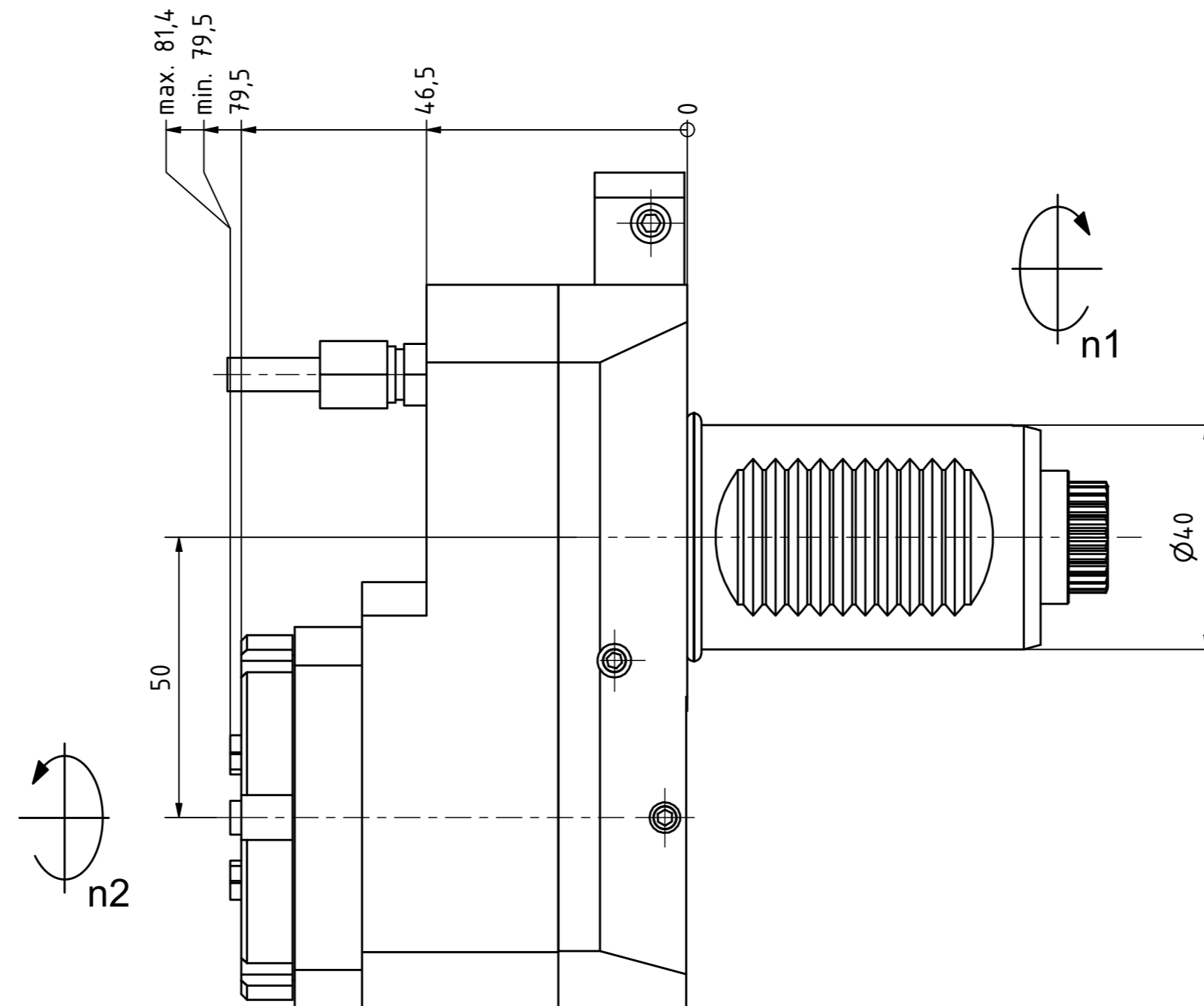

Spannzange / collet ER25 DIN6499
Spannbereich / clamping range: 1,0 - 16,0

Gewindebohrzange / tapping collet
ET-1-25 M3-M10

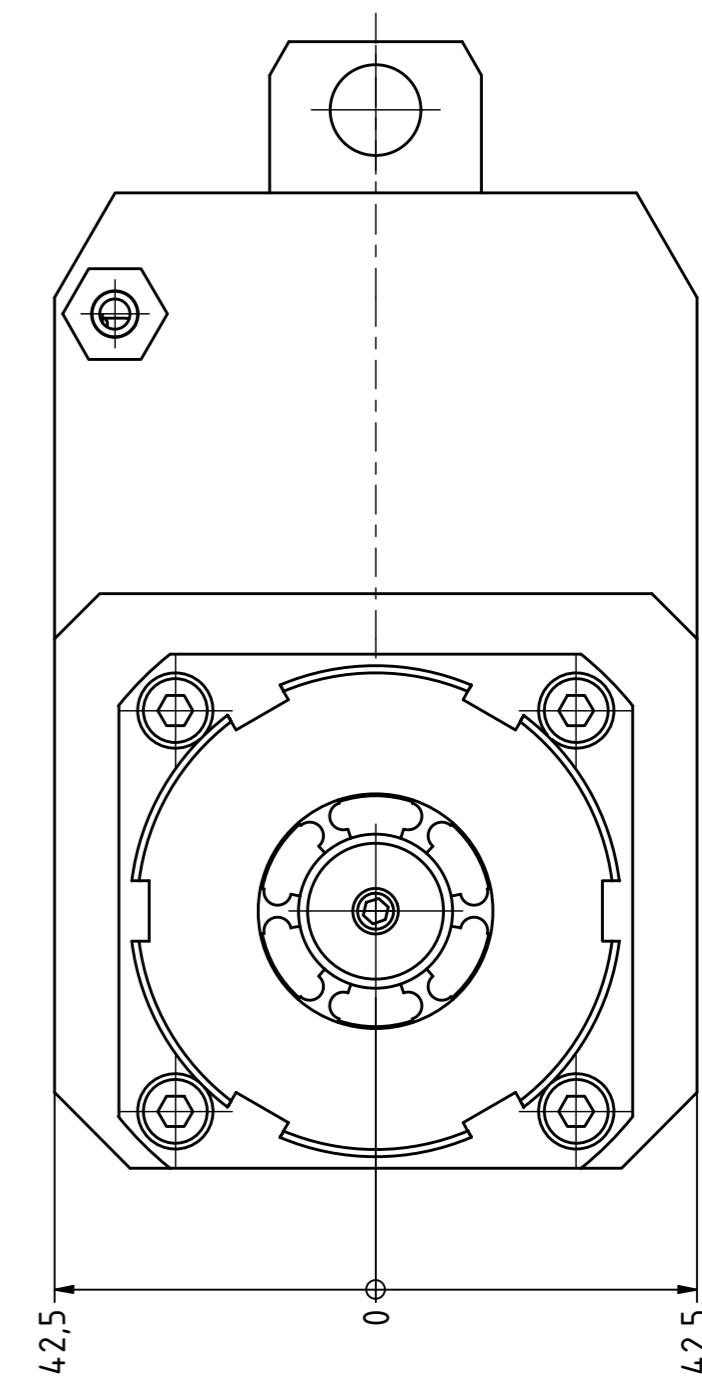

(1:2)

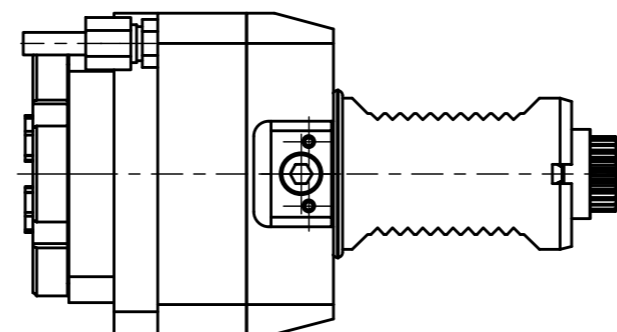

Doppelverzahnung Lizenz Traub
double tooth system licence Traub

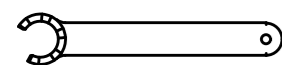
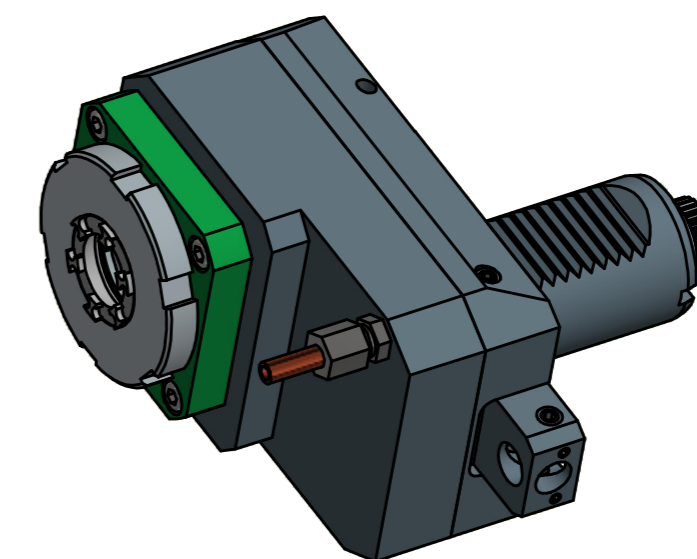

Spannzangenschlüssel für
innenliegende Mutter
Clamping wrench for
internal collet
225AX

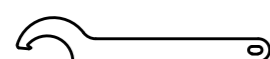

Hakenschlüssel
mit Nase
Hook wrench with
nose end
DIN1810 A 68x75

Copyright **EWS Tool Technologies**
Weitergabe und Vervielfältigung dieser Unterlage,
Verwertung und Mitteilung ihres Inhalts nicht
gestattet, soweit nicht ausdrücklich zugestanden.
Zuwerhandlungen verpflichten zu Schadenersatz.

Bemerkung - Note

Technische Daten - technical data

Weight = 5,096 [kg]
Torque max. (M1/M2) = 45 / 15 [Nm]
Speed max. (n1/n2) = 5000 / 15000 [1/min]
Gear ratio (i)=n1:n2 = 1:3

Benennung - Title

Axial Bohr u. Fräskopf achsversetzt
Ax. drill. and mill. head offset

EWS Tool Technologies
EWS Weigle GmbH & Co. KG
Maybachstr. 1
D-73066 Uhingen
www.ews-tool.de

Technische Änderungen vorbehalten!
Subject to technical modifications!
IDENT: D-EWS-004322

Nr. - No.
50.4025CTXRL131M

REV: -/-
MNR.
128319

QR