

Spannzange / collet ER40 DIN6499
 Spannungsbereich / clamping range: 3,0 - 26,0

Gewindebohrzange / tapping collet
 ET-1-40 M6-M16

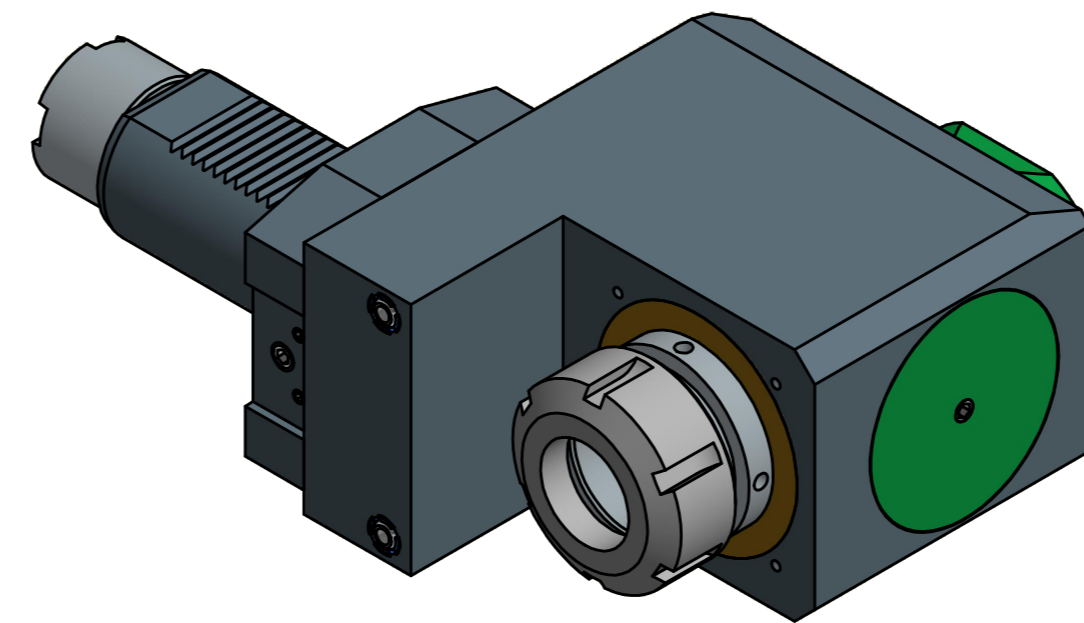
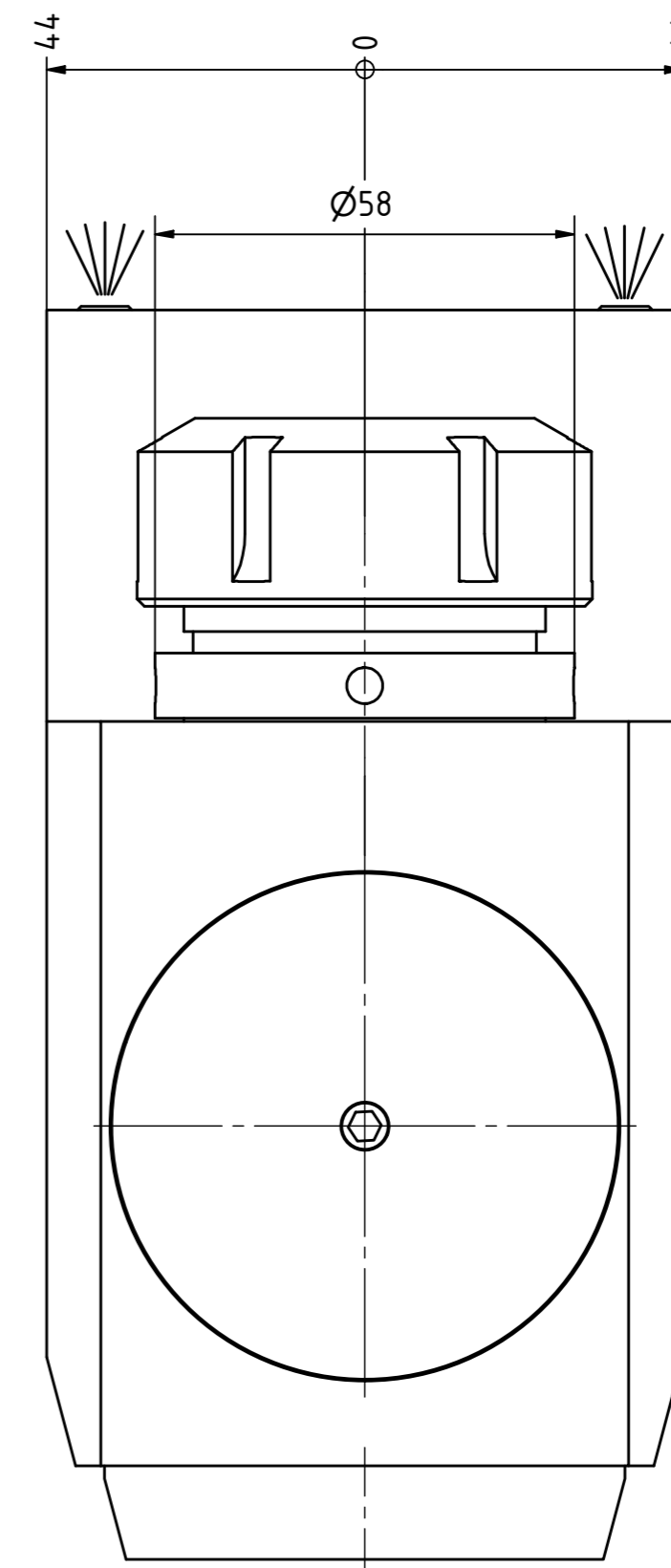
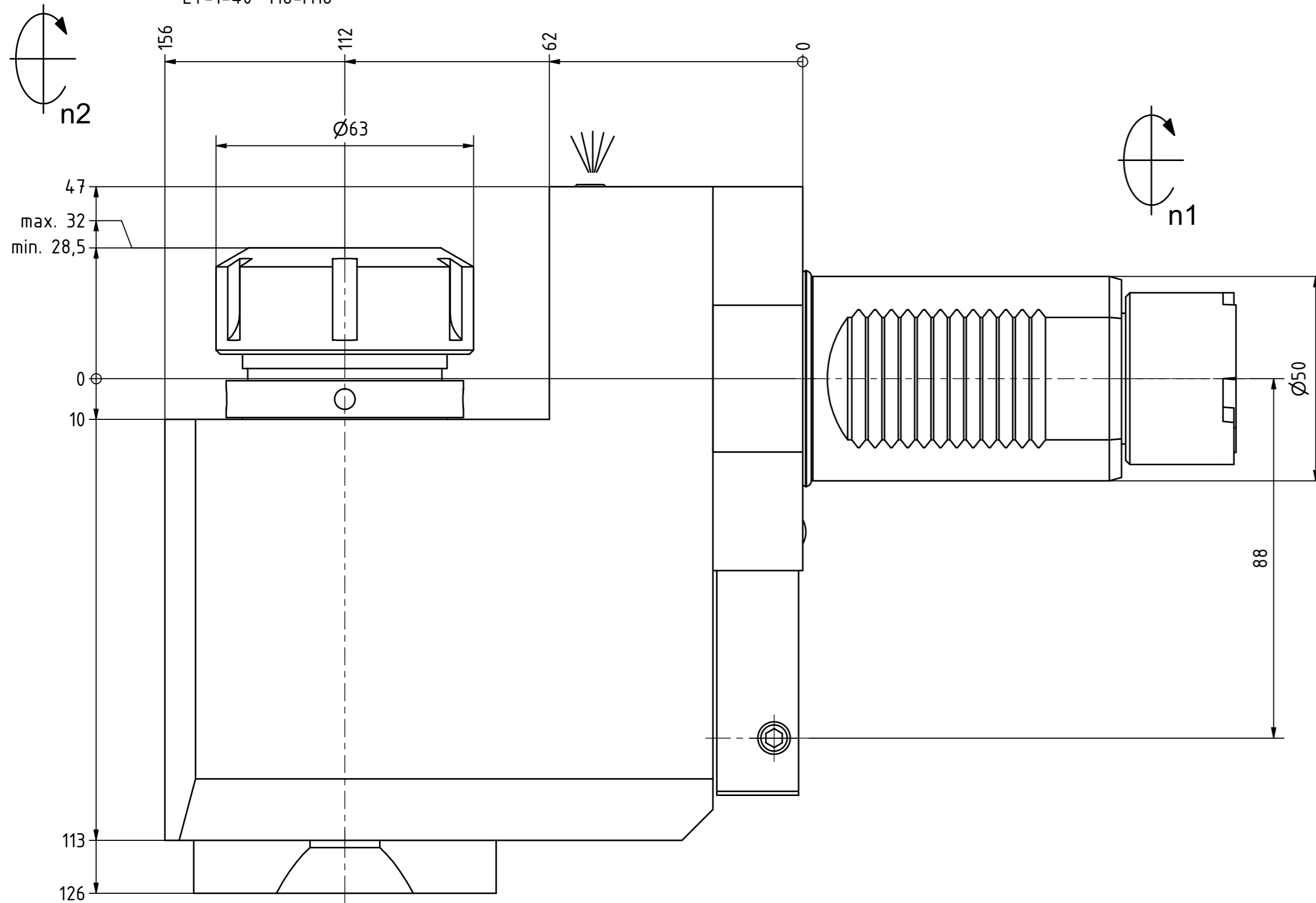

Copyright **EWS Tool Technologies**
 Weitergabe und Vervielfältigung dieser Unterlage,
 Verwertung und Mitteilung ihres Inhalts nicht
 gestattet, soweit nicht ausdrücklich zugestanden.
 Zuwiderhandlungen verpflichten zu Schadenersatz.

Bemerkung - Note

Technische Daten - technical data

Weight = 12.450 [kg]
 Torque max. (M1/M2) = 100 / 100 [Nm]
 Speed max. (n1/n2) = 4000 / 4000 [1/min]
 Gear ratio (i)=n1:n2 = 1:1

Benennung - Title

Radial Bohr und Fräskopf, zurückges
 Radial drill. and mill. head offset



Nr. - No.
 80.5040LU35L

Technische Änderungen vorbehalten!
 Subject to technical modifications!
 IDENT: D-EWS-123562

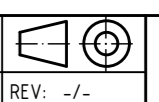

REV: -/-
 MNR.
 160701

