

Spannzange / collet ER25 DIN6499  
Spannbereich / clamping range: 1,0 - 16,0

Second pin must be pulled !

Doppelverzahnung Lizenz Traub  
double tooth system licence Traub

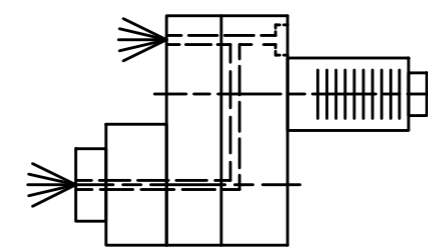
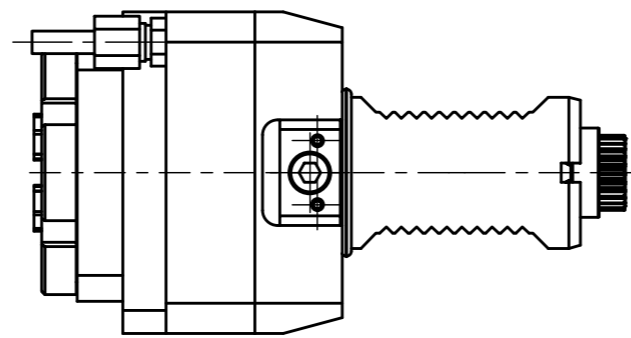

Spannzangenschlüssel für  
innenliegende Mutter  
Clamping wrench for  
internal collet  
225AX

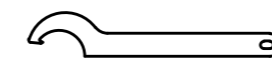

Hakenschlüssel  
mit Nase  
Hook wrench with  
nose end  
DIN1810 A 68x75

Innen- und Aussenkuehlung / Inside and outside coolant supply  
Kein Trockenlauf / No dry run  
Kuehlmittelfiltrierung <math>50\mu</math> / coolant filtration <math>50\mu</math>

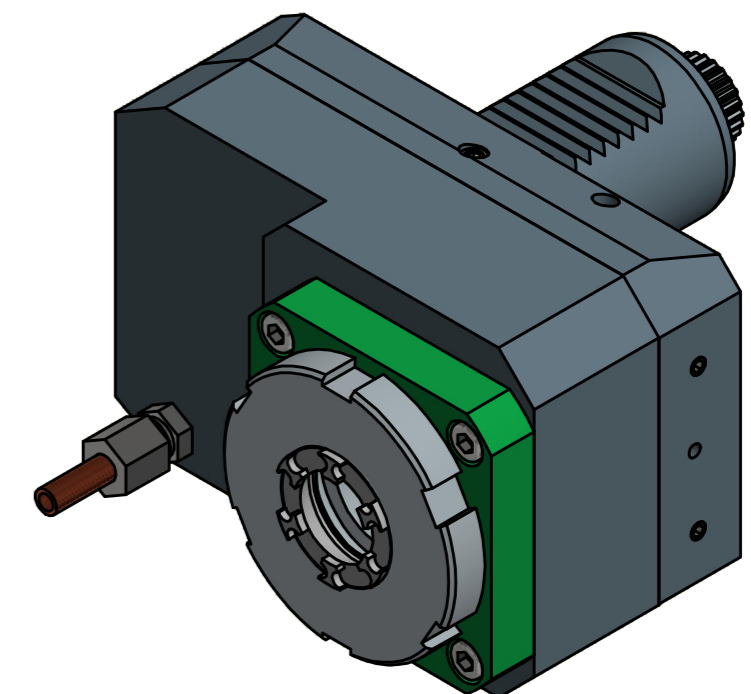

Copyright **EWS Tool Technologies**  
Weitergabe und Vervielfaeltigung dieser Unterlage,  
Verwertung und Mitteilung ihres Inhalts nicht  
gestattet, soweit nicht ausdrecklich zugestanden.  
Zuwaerhandlungen verpflichten zu Schadenersatz.

Bemerkung - Note <b>Nicht ohne Kuehlmittel betreiben!</b> <i>Not for use without coolant-fluid!</i>	Technische Daten - technical data Weight = 5.098 [kg] Torque max. (M1/M2) = 45 / 15 [Nm] Speed max. (n1/n2) = 5000 / 15000 [1/min] Gear ratio (i) = n1:n2 = 1:3 Pressure (pmax) = 70 [bar]
---	---

Benennung - Title  
**Axial Bohr u. Fräskopf achsversetzt**  
*Ax. drill. and mill. head offset*

<b>EWS</b> <small>Tool Technologies</small> EWS Weigle GmbH & Co. KG Maybachstr. 1 D-73066 Uhlingen www.ews-tools.de	Technische Aenderungen vorbehalten! <i>Subject to technical modifications!</i> IDENT: D-EWS-004328	 REV: -/- MNR. <b>128237</b>
Nr. - No. <b>50.4025CTXRLIK113IM</b>		

**QR**