

Spannzange / collet ER25 DIN6499
 Spannbereich / clamping range: 1,0 - 16,0

Gewindebohrzange / tapping collet
 ET-1-25 M3-M12

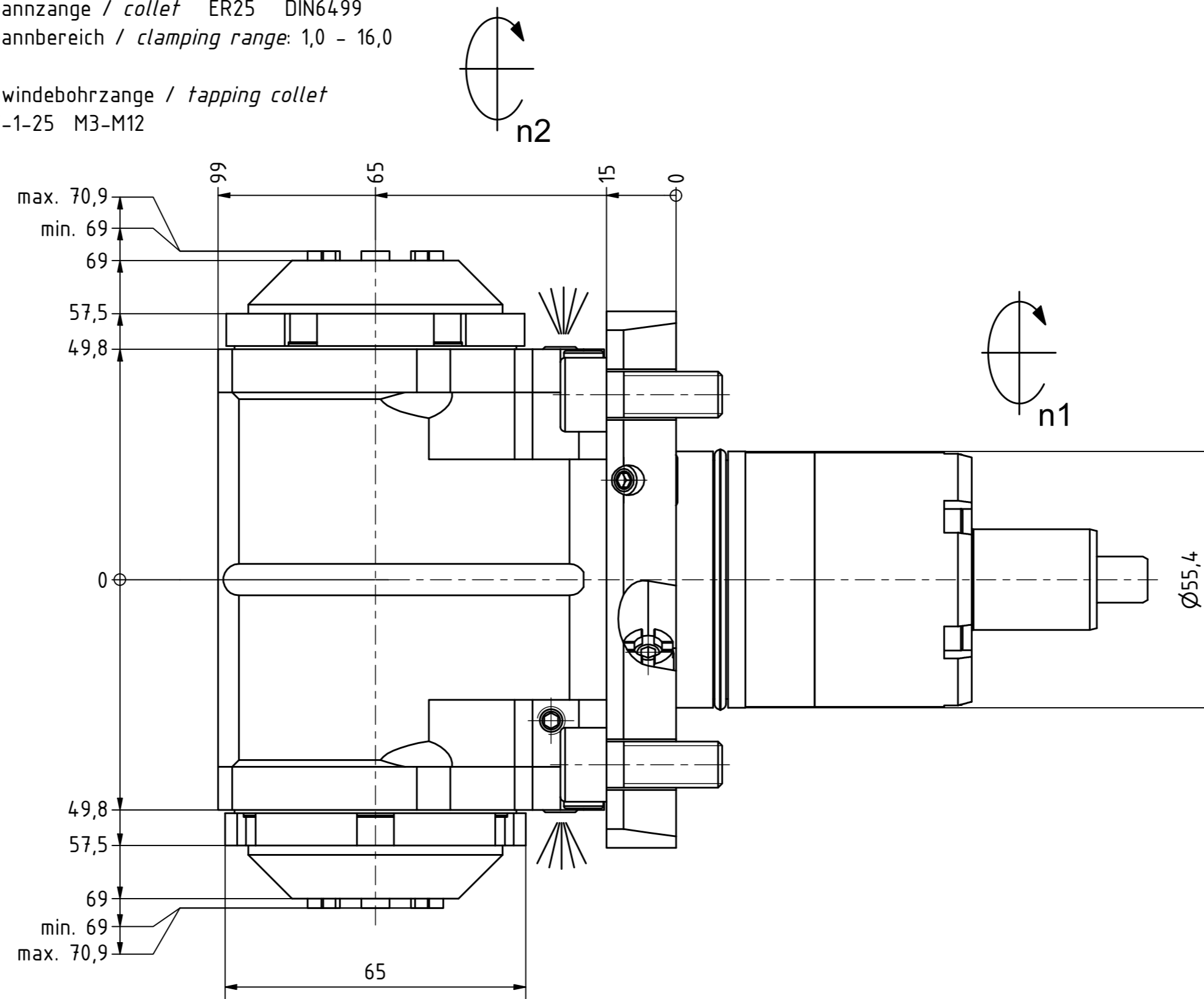
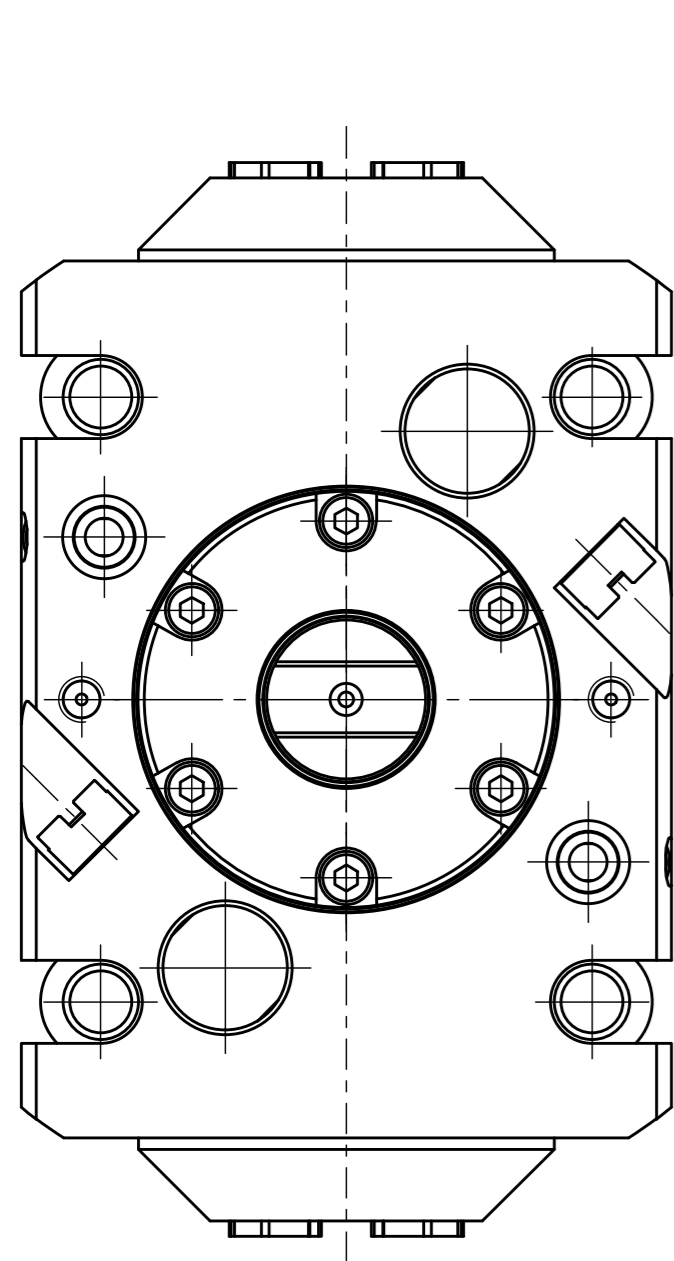

Spannzange / collet ER25 DIN6499
 Spannbereich / clamping range: 1,0 - 16,0

Gewindebohrzange / tapping collet
 ET-1-25 M3-M12

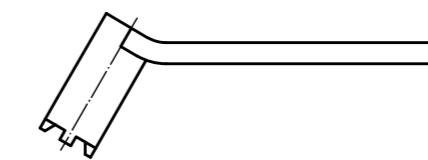
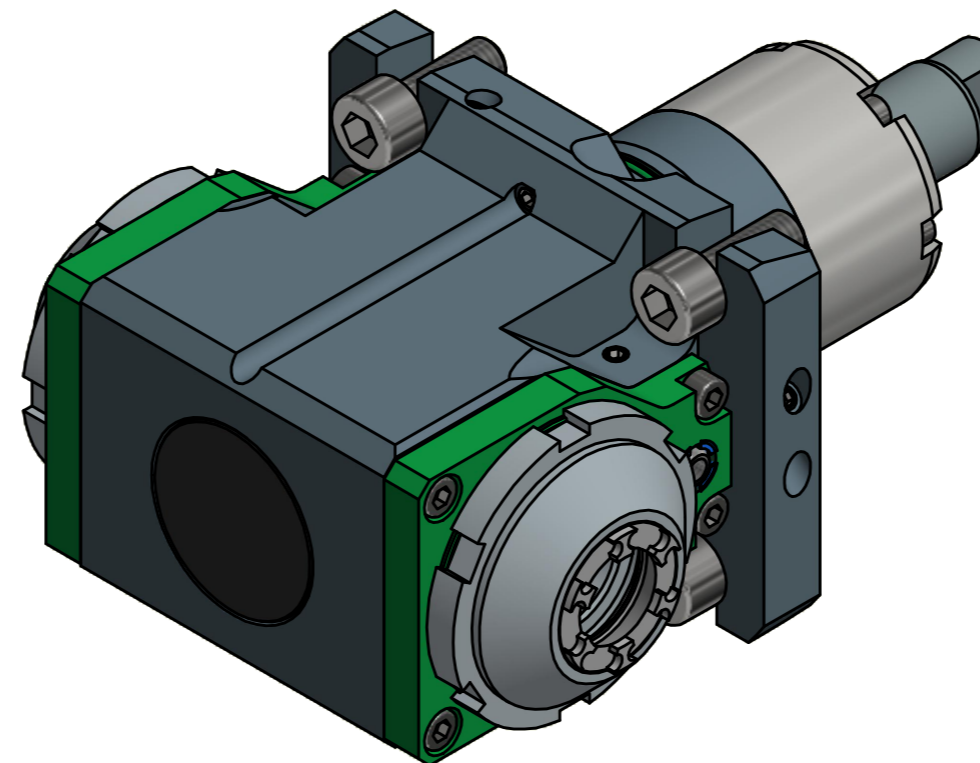
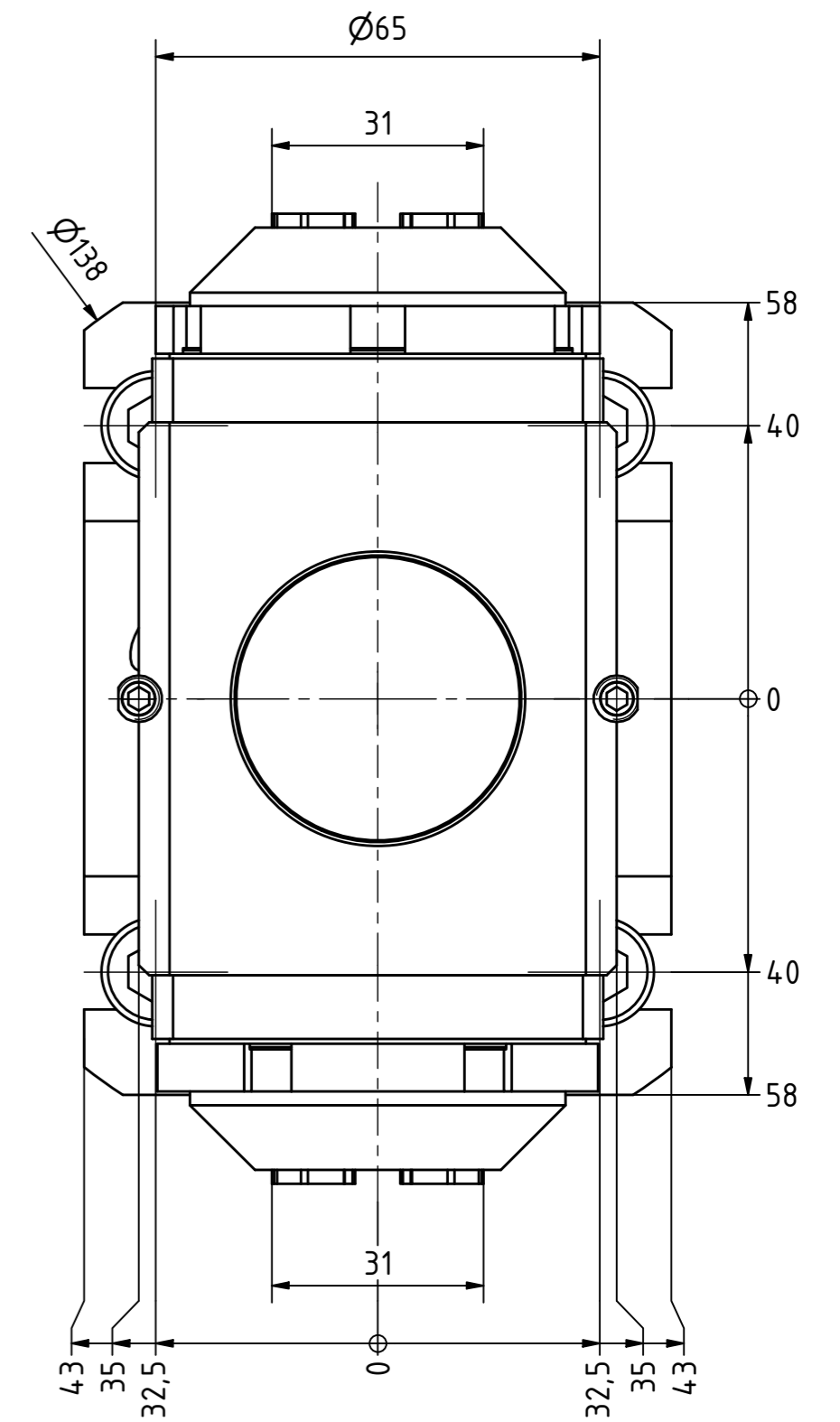

Schlüssel für Ausrichtung
 im Lieferumfang enthalten.
 Wrench for adjustment
 included in delivery
 AZS-LT2000

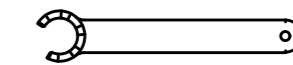

Spannzangenschlüssel für
 innenliegende Mutter
 Clamping wrench for
 internal collet
 225AX

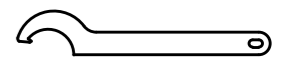

Hakenschlüssel
 mit Nase
 Hook wrench with
 nose end
 DIN1810 A 58x62

Copyright **EWS Tool Technologies**
 Weitergabe und Vervielfältigung dieser Unterlage,
 Verwertung und Mitteilung ihres Inhalts nicht
 gestattet, soweit nicht ausdrücklich zugestanden.
 Zuwiderhandlungen verpflichten zu Schadenersatz.

Bemerkung - Note 	Technische Daten - technical data Weight = 5,923 [kg] Torque max. (M1/M2) = 32 / 32 32 [Nm] Speed max. (n1/n2) = 6000 / 6000 6000 [1/min] Gear ratio (i)=n1:n2 = 1:1 1:1	Benennung - Title Radial Bohr und Fräskopf Radial drilling and milling head	<table border="1"> <tr> <td data-bbox="2226 1915 2463 1984"> EWS <small>EWS Weigle GmbH & Co. KG Maybachstr. 1 D-73066 Ulm/ingen www.ews-tools.de</small> </td> <td data-bbox="2463 1915 2671 1984"> <small>Technische Änderungen vorbehalten! Subject to technical modifications!</small> IDENT: DEWS088297 </td> <td data-bbox="2671 1915 2929 1984"> REV: -/B MNR. </td> </tr> <tr> <td data-bbox="2226 1984 2463 2043"> <small>Nr. - No.</small> 60.55.425DLT2000V16IM </td> <td data-bbox="2463 1984 2671 2043"> 157124 </td> <td data-bbox="2671 1984 2929 2043"> QR </td> </tr> </table>	EWS <small>EWS Weigle GmbH & Co. KG Maybachstr. 1 D-73066 Ulm/ingen www.ews-tools.de</small>	<small>Technische Änderungen vorbehalten! Subject to technical modifications!</small> IDENT: DEWS088297	 REV: -/B MNR.	<small>Nr. - No.</small> 60.55.425DLT2000V16IM	157124	QR
EWS <small>EWS Weigle GmbH & Co. KG Maybachstr. 1 D-73066 Ulm/ingen www.ews-tools.de</small>	<small>Technische Änderungen vorbehalten! Subject to technical modifications!</small> IDENT: DEWS088297	 REV: -/B MNR.							
<small>Nr. - No.</small> 60.55.425DLT2000V16IM	157124	QR							