

Spannzange / collet ER25 DIN6499
Spannbereich / clamping range: 1,0 - 16,0

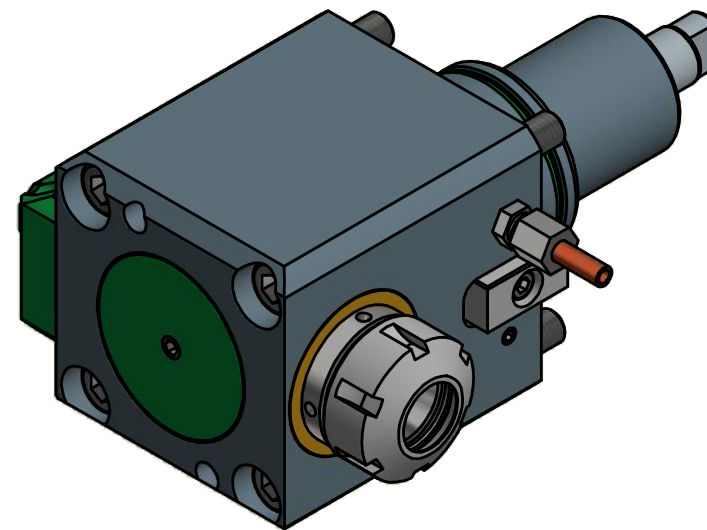

Innen- und Aussenkuehlung / Inside and outside coolant supply
Kein Trockenlauf / No dry run
Kuehlmittelfiltrierung 50μ / coolant filtration 50μ

Copyright **EWS Tool Technologies**
Weitergabe und Vervielfaeltigung dieser Unterlage,
Verwertung und Mitteilung ihres Inhalts nicht
gestattet, soweit nicht ausdrecklich zugestanden.
Zuwiderhandlungen verpflichten zu Schadenersatz.

Bemerkung - Note
Nicht ohne Kuehlmittel betreiben!
Not for use without coolant-fluid!

Technische Daten - technical data	
Weight	= 6.134 [kg]
Torque max. (M1/M2)	= 25 / 25 [Nm]
Speed max. (n1/n2)	= 6000 / 6000 [1/min]
Gear ratio (i)=n1:n2	= 1:1
Pressure (pmax)	= 70 [bar]

Benennung - Title
Radial Bohr und Fräskopf
Radial drilling and milling head



Nr. - No.
60.55251809N4IKGLX70

Technische Aenderungen vorbehalten!
Subject to technical modifications!
IDENT: DEWS097990

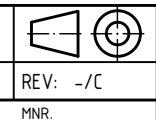

REV: -/C
MNR.
158097

