

Spannzange / collet ER32 DIN6499
 Spannereich / clamping range: 2,0 - 20,0

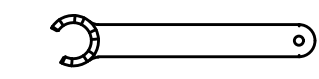

Spannzangenschlüssel für
 innenliegende Mutter
*Clamping wrench for
 internal collet*
232AX

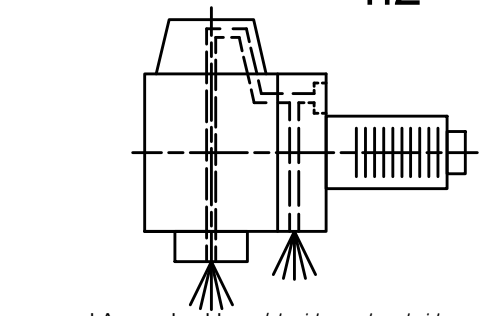
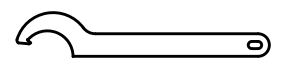

Hakenschlüssel
 mit Nase
*Hook wrench with
 nose end*
DIN1810 A 68x75

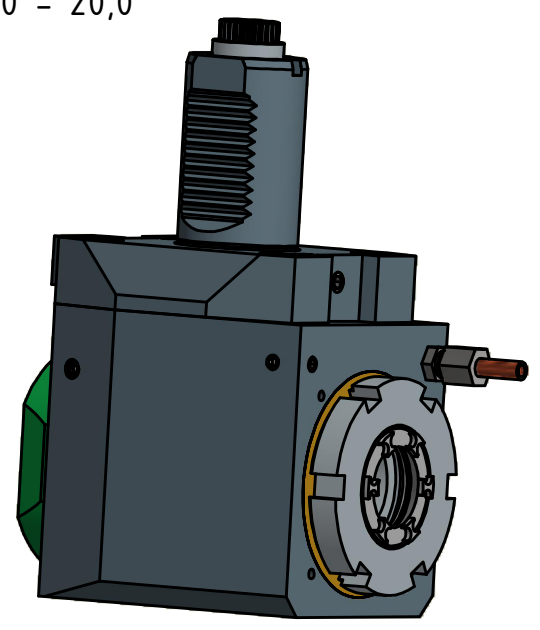

Innen- und Aussenkuehlung / Inside and outside coolant supply
 Kuehlmittelfiltrierung <math>< 50\mu</math> / coolant filtration <math>< 50\mu</math>

Copyright **EWS Tool Technologies**
 Weitergabe und Vervielfaeltigung dieser Unterlage,
 Verwertung und Mitteilung ihres Inhalts nicht
 gestattet, soweit nicht ausdrecklich zugestanden.
 Zuwiderhandlungen verpflichten zu Schadenersatz.

Bemerkung - Note
 Für Trockenlauf geeignet!
Use without coolant fluid allowed!

Technische Daten - technical data
 Weight = 7.400 [kg]
 Torque max. (M1/M2) = 50 / 50 [Nm]
 Speed max. (n1/n2) = 6000 / 6000 [1/min]
 Gear ratio (i) = n1:n2 = 1:1
 Pressure (pmax) = 70 [bar]

Benennung - Title
Radial Bohr und Fräskopf
Radial drilling and milling head

EWS Tool Technologies
 EWS Weigele GmbH & Co. KG
 Maybachstr. 1
 D-73066 UHINGEN
 www.ews-tools.de

Technische Aenderungen vorbehalten!
 Subject to technical modifications!
 IDENT: D-EWS-004833
 Nr. - No. 60.4032KCTXRIKDIM-BG50

REV: -/-
 MNR. 129536

