

Spannzange / collet ER40 DIN6499
 Spannbereich / clamping range: 3,0 - 26,0

Gewindebohrzange / tapping collet
 ET-1-40 M6-M16

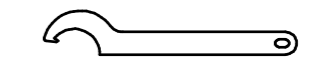

Hakenschlüssel
 mit Nase
 Hook wrench with
 nose end
 DIN1810 A 110x115

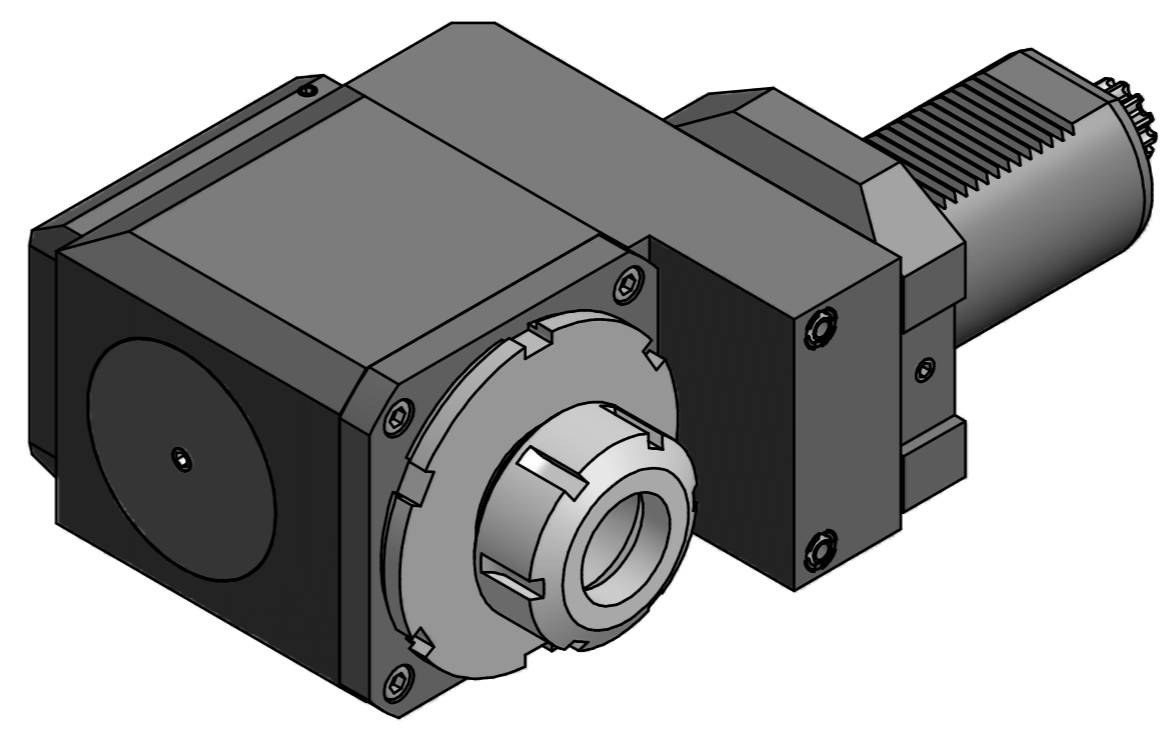
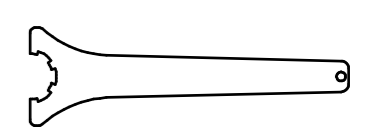

Spannzangenschlüssel
 Clamping wrench
 240

Copyright **EWS Tool Technologies**
 Weitergabe und Vervielfältigung dieser Unterlage,
 Verwertung und Mitteilung ihres Inhalts nicht
 gestattet, soweit nicht ausdrücklich zugestanden.
 Zuwiderhandlungen verpflichten zu Schadenersatz.

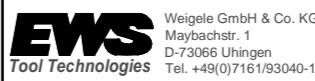
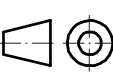
Bemerkung - Note mit Kegelrollenlager with taper roller bearing(s)	Technische Daten - Technical data M ₁ / M ₂ = 80 / 160 Nm n ₁ / n ₂ = 4000 / 2000 1/min i (N ₁ :N ₂) = 2:1	Benennung - Title Radial Bohr und Fräskopf. zurückges Radial drill. and mill. head offset	name	date	Technische Änderungen vorbehalten! Subject to technical modifications!	
			drawing	Theiss		10.05.2012
			 Weigete GmbH & Co. KG Maybachstr. 1 D-73066 Ulm/Ingden Tel. +49(0)7161/93040-10		Nr. 80.6040KR5482R12-BG50	 DIN A2
			MNR: 159433		IDENT: D-EWS-120489 -	