

Spannzange / collet ER25 DIN6499
 Spannbereich / clamping range: 1,0 - 16,0

Gewindebohrzange / tapping collet
 ET-1-25 M3-M10

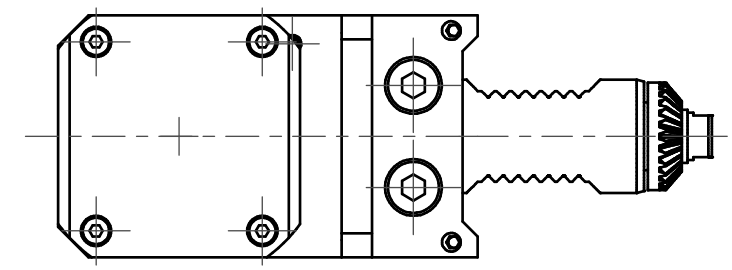

Doppelverzahnung Lizenz Traub
 double tooth system licence Traub

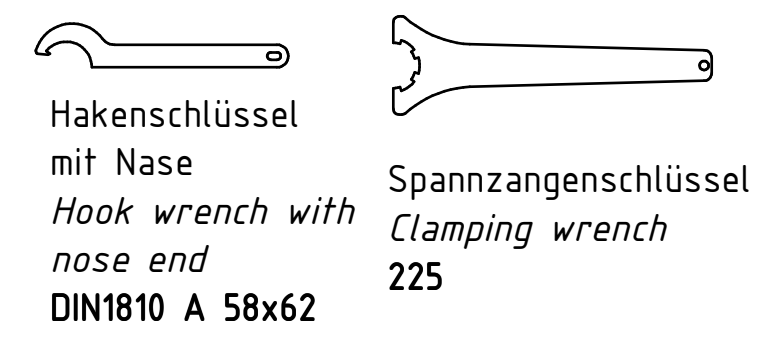
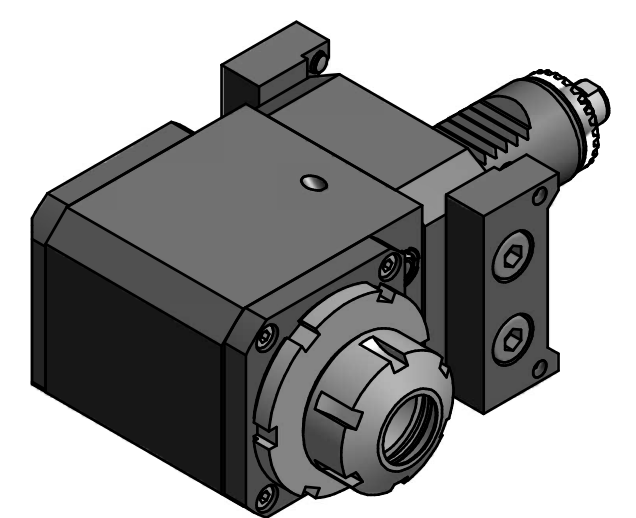

Copyright **EWS Tool Technologies**
 Weitergabe und Vervielfaeltigung dieser Unterlage,
 Verwertung und Mitteilung ihres Inhalts nicht
 gestattet, soweit nicht ausdrecklich zugestanden.
 Zuwiderhandlungen verpflichten zu Schadenersatz.

Bemerkung - Note mit Kegelrollenlager with taper roller bearing(s) Tmax Klemmbolzen Revolver = 25 Nm	Technische Daten - technical data M1 / M2 = 20 / 60 Nm n1 / n2 = 6000 / 2000 1/min i (N1:N2) = 3:1	Benennung - Title Radial Bohr und Fräskopf <i>Radial drilling and milling head</i>	<table border="1"> <tr> <th>name</th> <th>date</th> </tr> <tr> <td>Schmid</td> <td>13.03.2007</td> </tr> </table>	name	date	Schmid	13.03.2007	Technische Aenderungen vorbehalten! Subject to technical modifications! Nr. 60.3025KRTNC65RLI3 MNR: 128783 IDENT: D-EWS-009847 - Blatt - page 1 (1)
name	date							
Schmid	13.03.2007							