

Spannzange / collet ER25 DIN6499  
 Spannungsbereich / clamping range: 1,0 - 16,0

Gewindebohrzange / tapping collet  
 ET-1-25 M3-M10

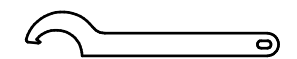

Hakenschlüssel  
 mit Nase  
 Hook wrench with  
 nose end  
 DIN1810 A 58x62

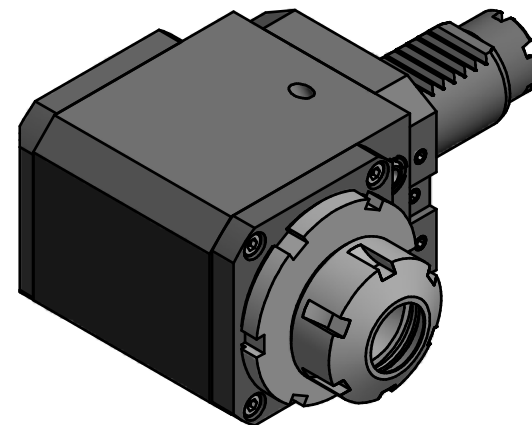
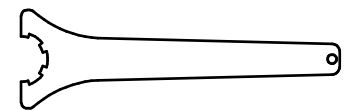

Spannzangenschlüssel  
 Clamping wrench  
 225

Copyright **EWS Tool Technologies**  
 Weitergabe und Vervielfältigung dieser Unterlage,  
 Verwertung und Mitteilung ihres Inhalts nicht  
 gestattet, soweit nicht ausdrücklich zugestanden.  
 Zuwiderhandlungen verpflichten zu Schadenersatz.

Bemerkung - Note  
 mit Kegelrollenlager  
 with taper roller bearing(s)

Technische Daten - technical data  
 Weight = 3.247 [kg]  
 Torque max. (M1/M2) = 20 / 60 [Nm]  
 Speed max. (n1/n2) = 6000 / 2000 [1/min]  
 Gear ratio (i)=n1:n2 = 3:1

Benennung - Title  
**Radial Bohr und Fräskopf**  
**Radial drilling and milling head**



Nr. - No.  
**60.3025KRT0EMR13**

Technische Änderungen vorbehalten!  
 Subject to technical modifications!

IDENT: D-EWS-005904



REV: A/-

MNR.  
**129463**

