

Spannzange / collet ER20 DIN6499  
 Spannereich / clamping range: 1,0 - 13,0

Gewindebohrzange / tapping collet  
 ET-1-20 M2-M6

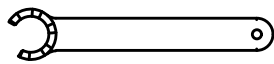

Spannzangenschlüssel für  
 innenliegende Mutter  
 Clamping wrench for  
 internal collet

220AX

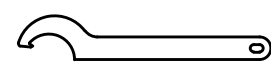

Hakenschlüssel  
 mit Nase  
 Hook wrench with  
 nose end

DIN1810 A 45x50

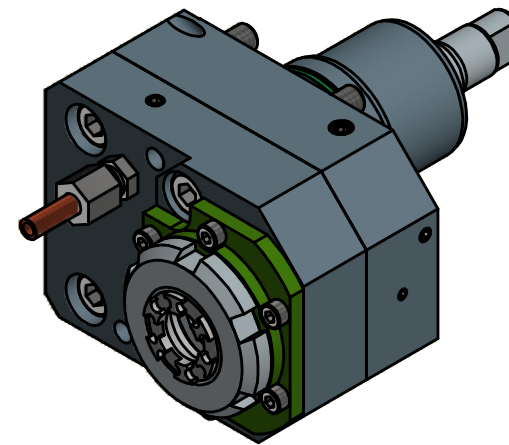

Copyright **EWS Tool Technologies**  
 Weitergabe und Vervielfältigung dieser Unterlage,  
 Verwertung und Mitteilung ihres Inhalts nicht  
 gestattet, soweit nicht ausdrücklich zugestanden.  
 Zuwiderhandlungen verpflichten zu Schadenersatz.

Bemerkung - Note

Technische Daten - technical data

Benennung - Title

Weight = 3.604 [kg]  
 Torque max. (M1/M2) = 24 / 12 [Nm]  
 Speed max. (n1/n2) = 6000 / 12000 [1/min]  
 Gear ratio (i)=n1:n2 = 1:2

**Axial Bohr u. Fräskopf achsversetzt**  
**Ax. drill. and mill. head offset**



Nr. - No.  
**50.4420NTY311M**

Technische Änderungen vorbehalten!  
 Subject to technical modifications!

IDENT: DEWS049707

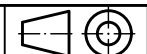

REV: -/A

MNR.

**159379**

