

Fraeserwelle austauschbar
Spindle removable

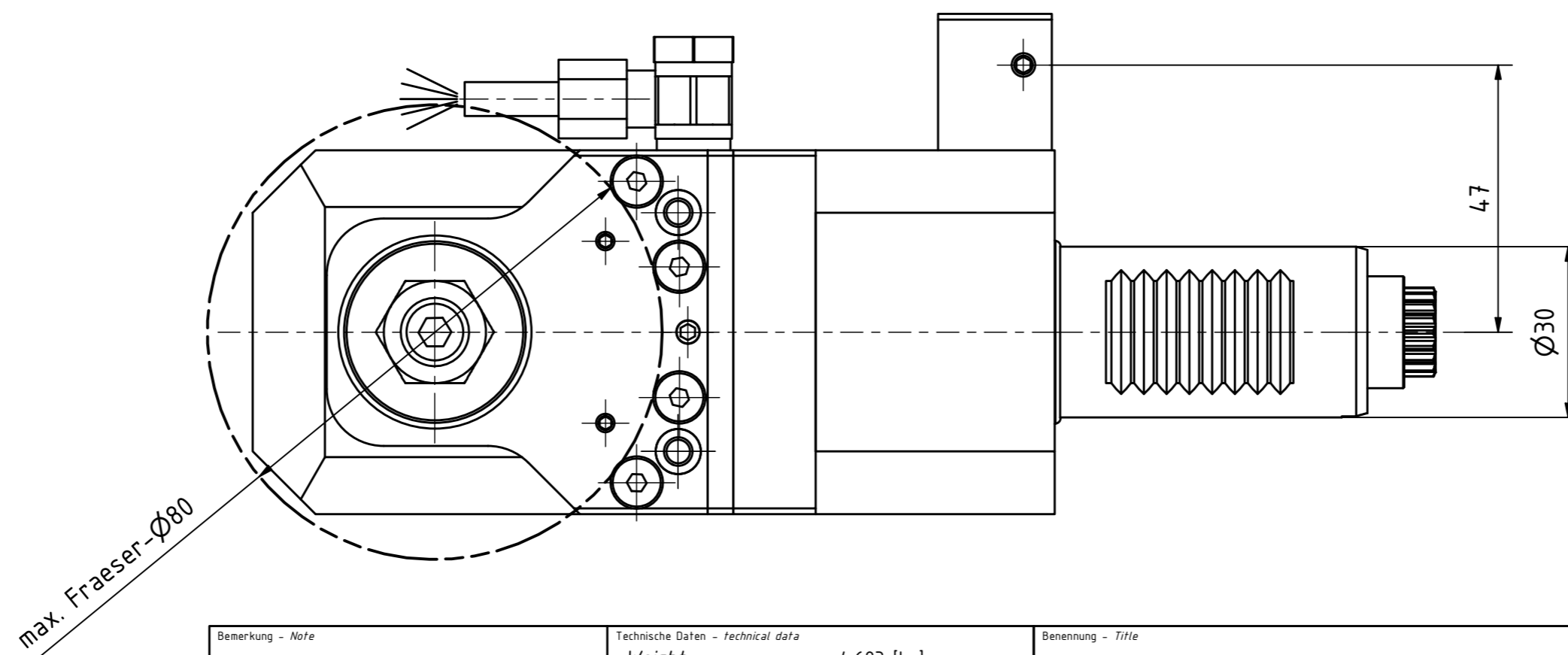
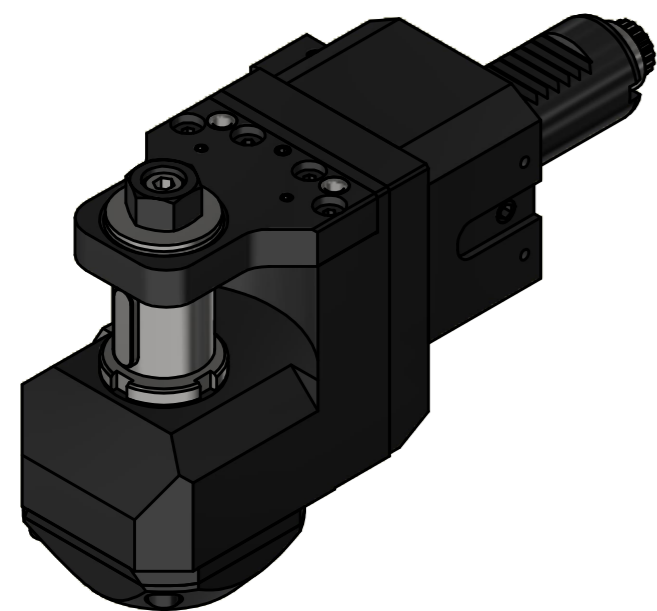
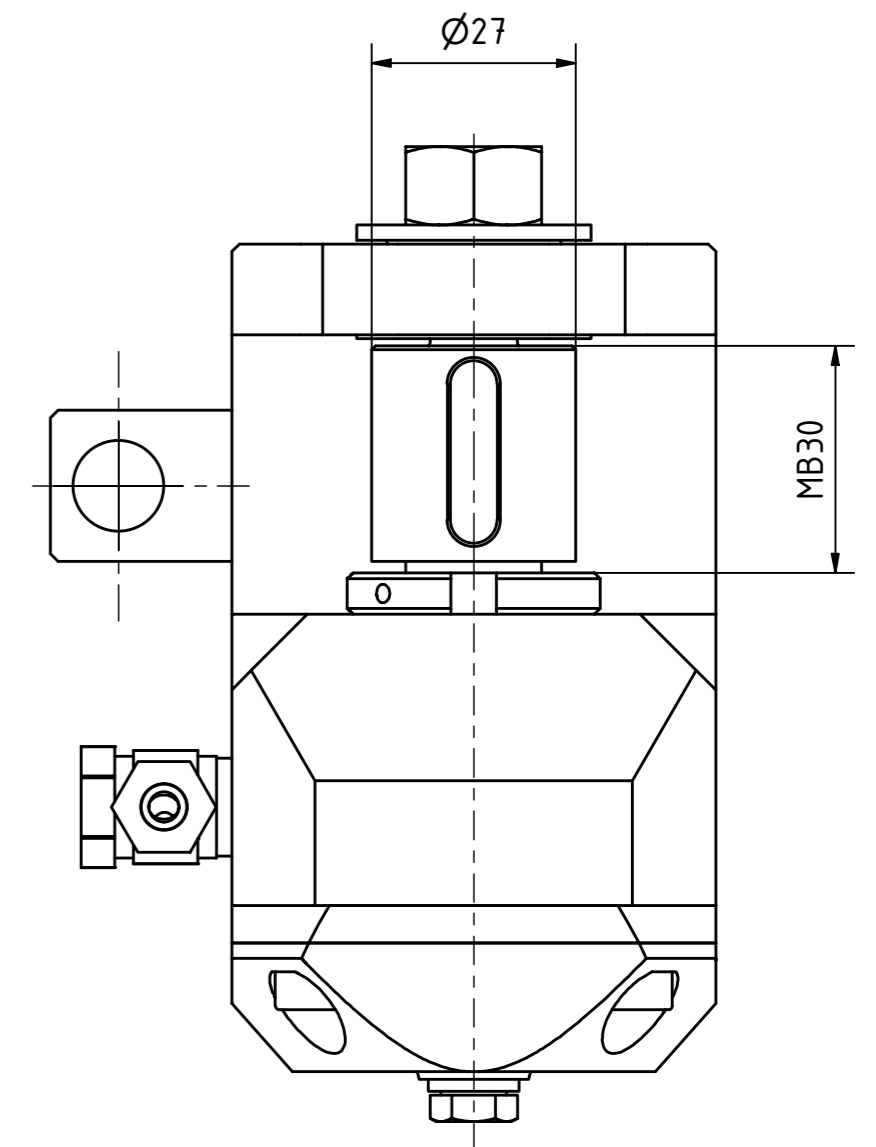
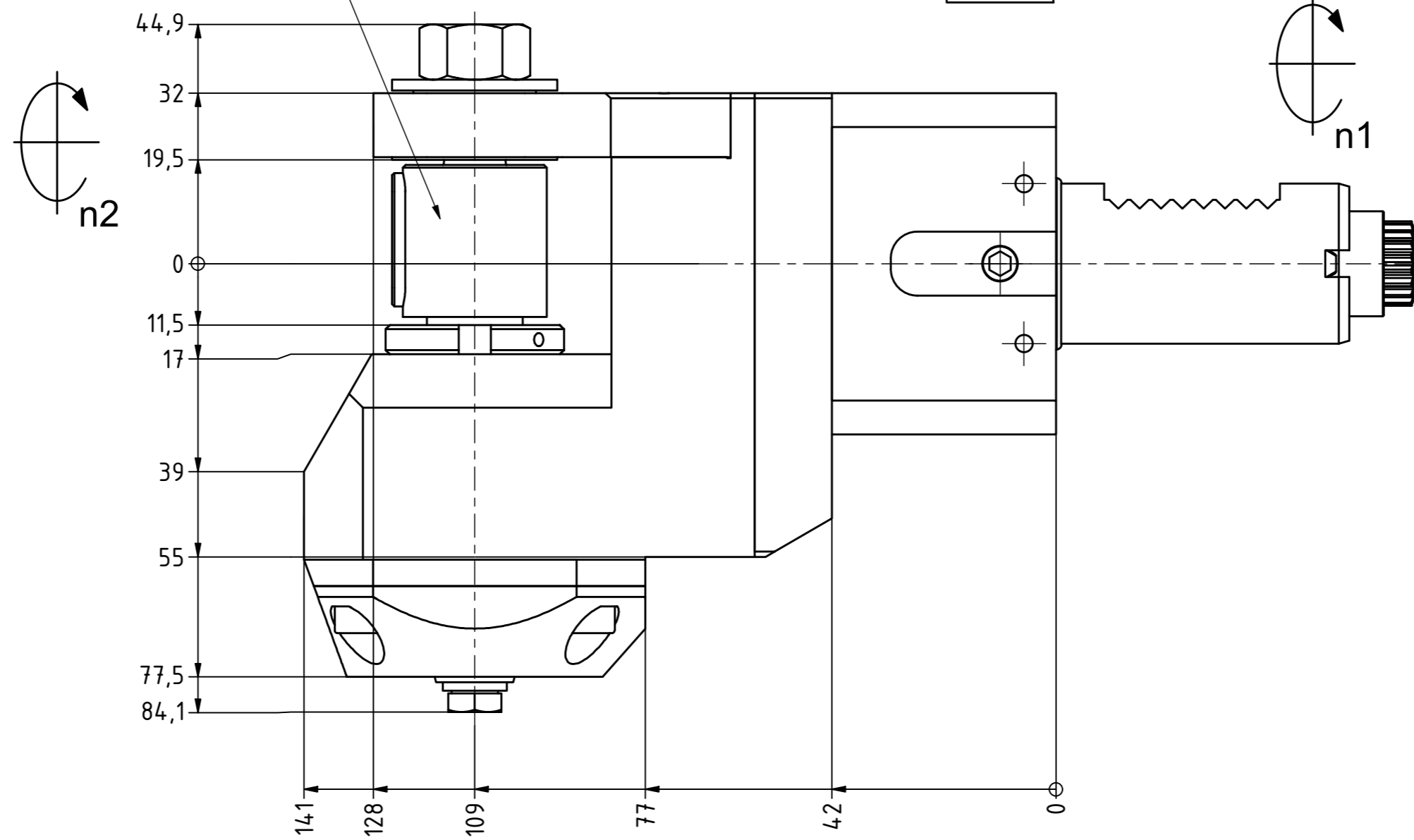

Copyright **EWS Tool Technologies**
Weitergabe und Vervielfältigung dieser Unterlage,
Verwertung und Mitteilung ihres Inhalts nicht
gestattet, soweit nicht ausdrücklich zugestanden.
Zuwerhandlungen verpflichten zu Schadenersatz.

Bemerkung - Note

Technische Daten - technical data

Weight = 4,683 [kg]
Torque max. (M1/M2) = 20 / 60 [Nm]
Speed max. (n1/n2) = 6000 / 2000 [1/min]
Gear ratio (i)=n1:n2 = 3:1

Benennung - Title

Scheibenfräserkopf
Radial saw milling head



EWS Weigle GmbH & Co. KG
Maybachstr. 1
D-73066 Uhlingen
www.ews-tools.de

Technische Änderungen vorbehalten!
Subject to technical modifications!
IDENT: D-EWS-004128

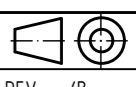

REV: -/B
MNR.
128077

Nr. - No.
64.3027LCTX13

