

Spannzange / collet ER40 DIN6499
 Spannbereich / clamping range: 3,0 - 26,0

Innen- und Aussenkuehlung / Inside and outside coolant supply
 Kein Trockenlauf / No dry run
 Kuehlmittelfiltrierung 50μ / coolant filtration 50μ

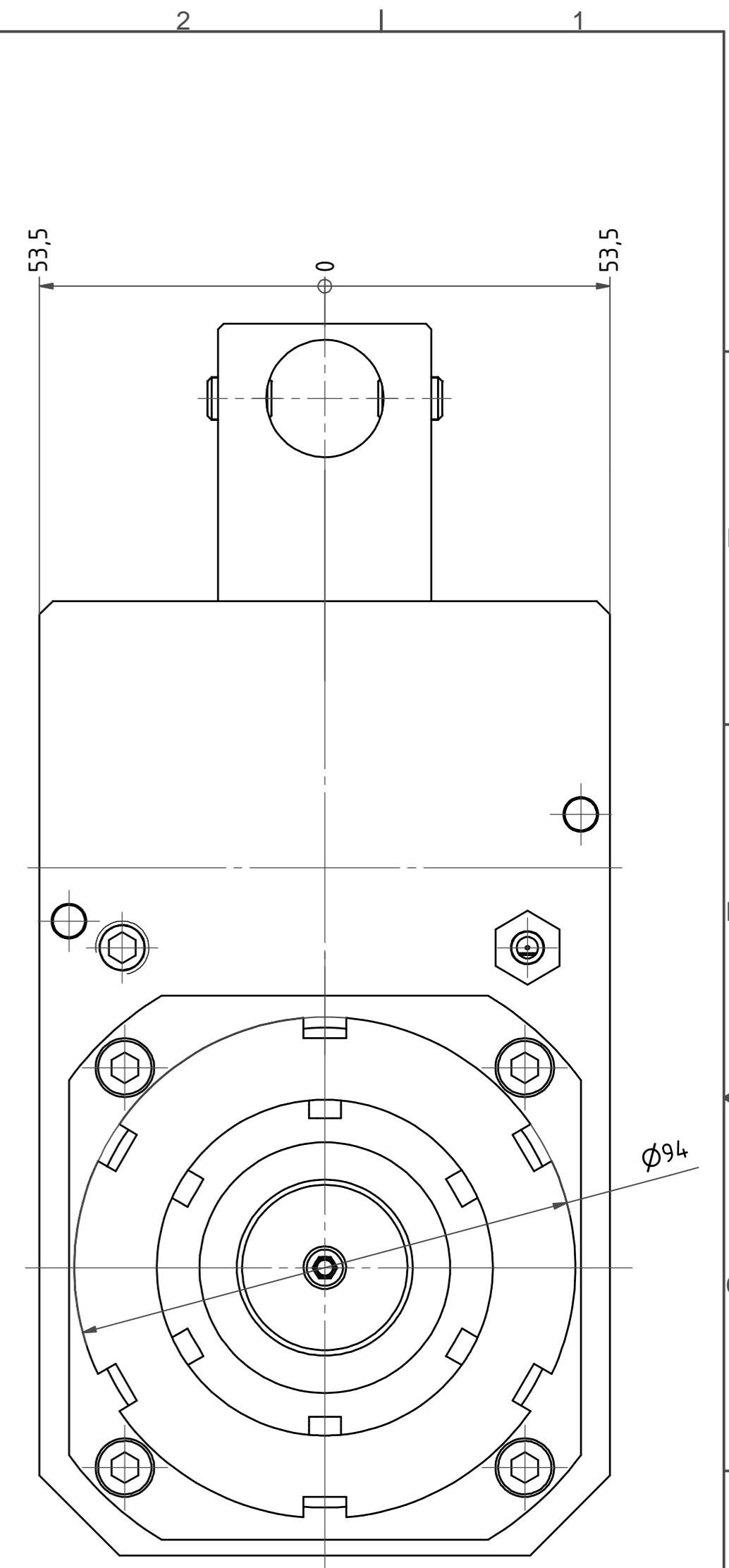
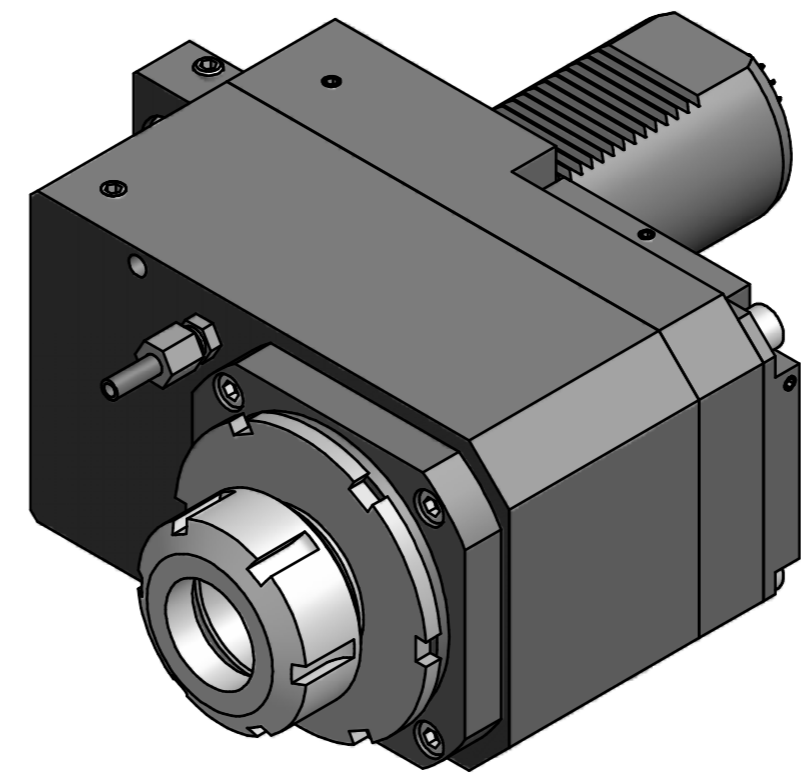

Spannzangenschlüssel
 Clamping wrench
 240

Spannzangenschlüssel
 Clamping wrench
 240

Copyright **EWS Tool Technologies**
 Weitergabe und Vervielfaeltigung dieser Unterlage,
 Verwertung und Mitteilung ihres Inhalts nicht
 gestattet, soweit nicht ausdrecklich zugestanden.
 Zuwiderhandlungen verpflichten zu Schadenersatz.

Bemerkung - Note Nicht ohne Kuehlmittel betreiben! Not for use without coolant-Fluid! mit Kegelrollenlagern with taper roller bearings	Technische Daten - Technical data M1 / M2 = 80 / 160 Nm n1 / n2 = 4000 / 2000 1/min i (N1:N2) = 2:1 Pmax = 70 bar
--	---

Benennung - Title
Axial Bohr u. Fräskopf achsversetzt
Ax. drill. and mill. head offset

name Theiss	date 14.08.2012	Technische Aenderungen vorbehalten! Subject to technical modifications!
Nr. 50.6040KR5482RIK12		DIN A2
MNR: 157946	IDENT: D-EWS-124423 -	Blatt - page 1 (1)