

Innen- und Aussenkuehlung / Inside and outside coolant supply
 Kein Trockenlauf / No dry run
 Kuehlmittelfiltrierung 50μ / coolant filtration 50μ

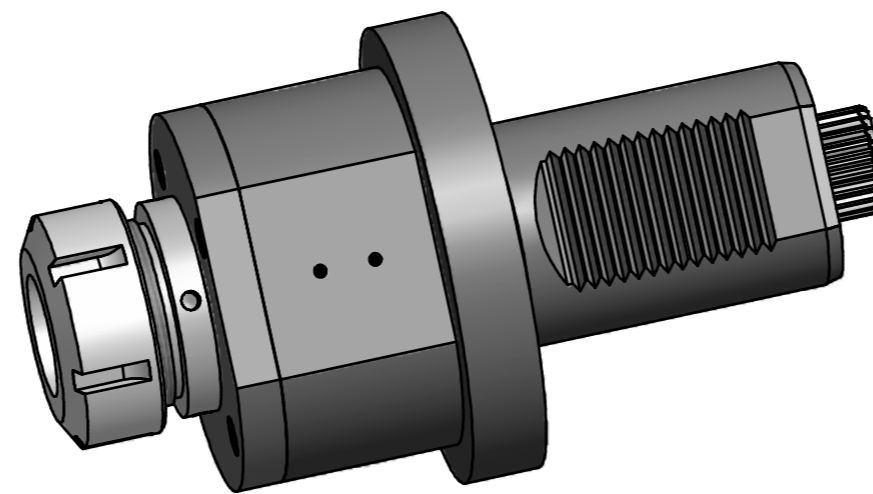

Copyright **EWS Tool Technologies**
 Weitergabe und Vervielfaeltigung dieser Unterlage,
 Verwertung und Mitteilung ihres Inhalts nicht
 gestattet, soweit nicht ausdrecklich zugestanden.
 Zuwiderhandlungen verpflichten zu Schadenersatz.

Bemerkung - Note Nicht ohne Kuehlmittel betreiben! Not for use without coolant-fluid!	Technische Daten - Technical data M1 / M2 = 160 / 160 Nm n1 / n2 = 3000 / 3000 1/min i (N1:N2) = 1:1 Pmax = 25 bar		Benennung - Title Axial Bohr und Fräskopf Axial drilling and milling head	name Schmid	date 13.03.2007	Technische Aenderungen vorbehalten! Subject to technical modifications! Nr. 40.6040DOSIK File: 40.60405480IK_OUT.idw	DIN A2 Blattum page 7 of 3
	EWS Tool Technologies <small>Weigle GmbH & Co. KG Maybachstr. 1 D-70864 Uhingen Tel. +49(0)7161/93040-10</small>						