

Schwenkbereich ±105°
Swivel area ±105°

Spannzange / collet ER25 DIN6499
Spannbereich / clamping range: 1,0 - 16,0

Gewindebohrzange / tapping collet
ET-1-25 M3-M10

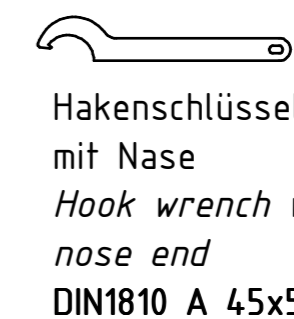
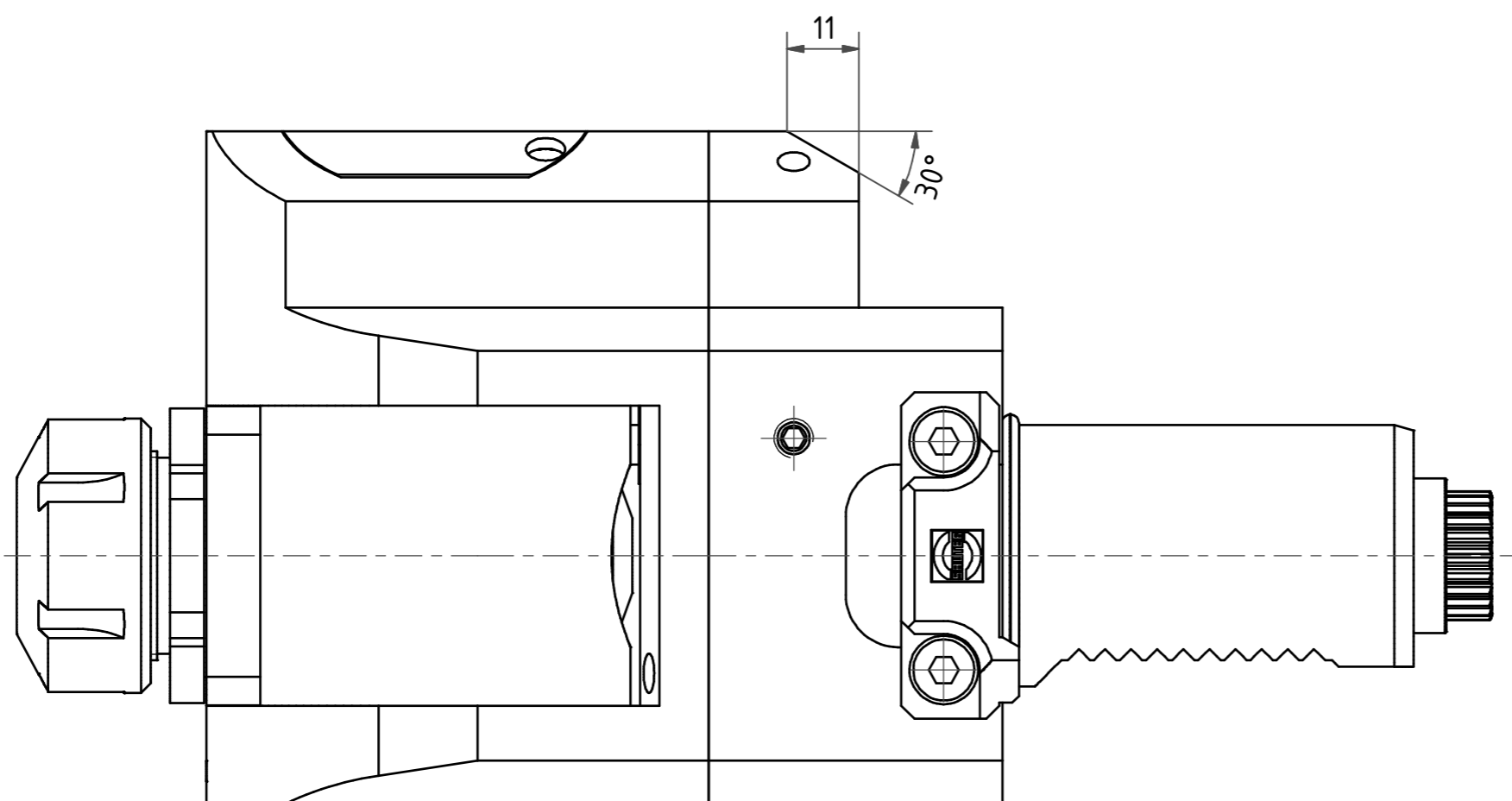
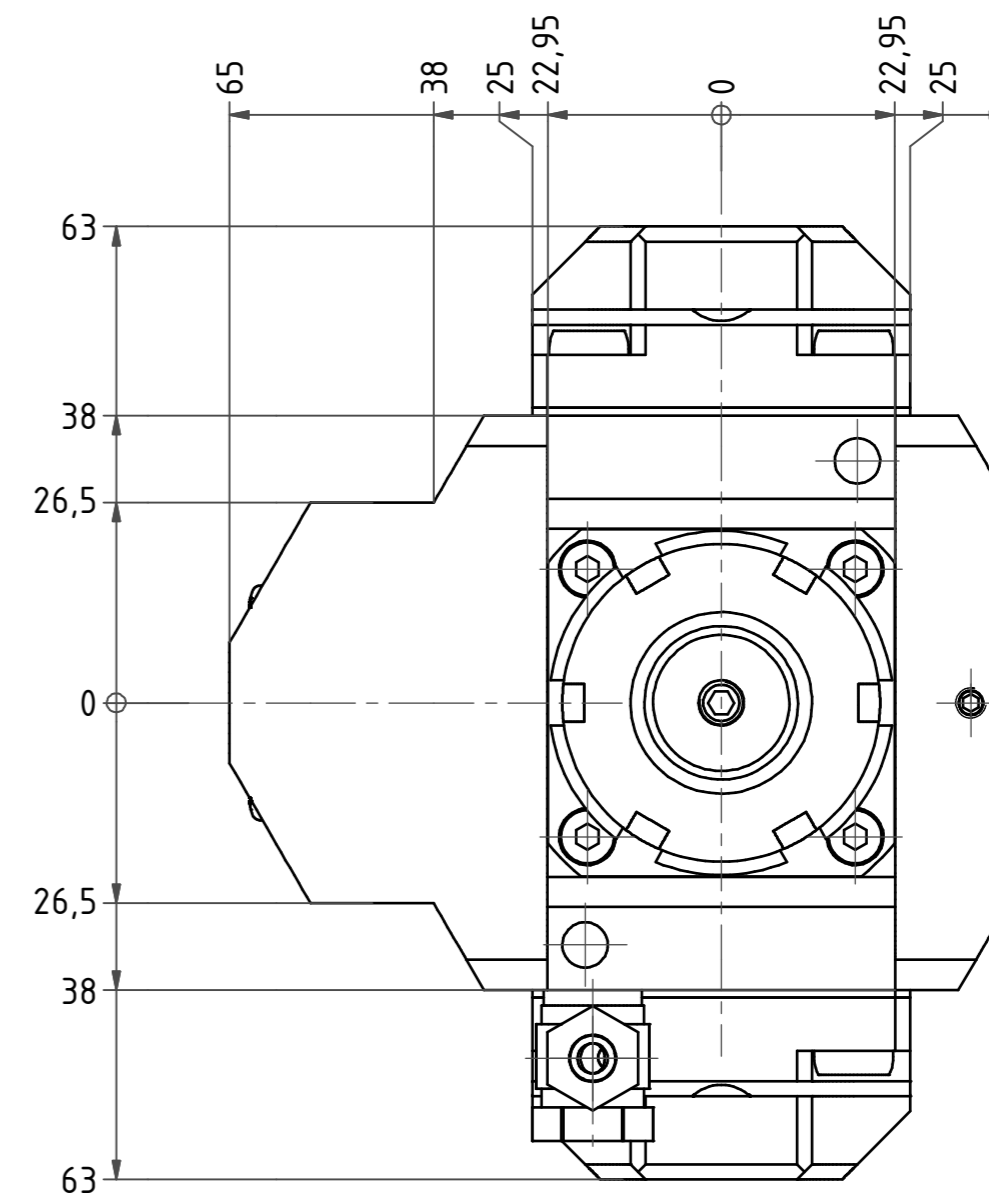

Copyright **EWS Tool Technologies**
Weitergabe und Vervielfältigung dieser Unterlage,
Verwertung und Mitteilung ihres Inhalts nicht
gestattet, soweit nicht ausdrücklich zugestanden.
Zuwendungen verpflichten zu Schadenersatz.

Benennung - Title	Technische Daten - Technical data		Benennung - Title	name	date	Technische Änderungen vorbehalten! Subject to technical modifications!
	M ₁ / M ₂ = 20 / 20 Nm n ₁ / n ₂ = 10000 / 10000 1/min i (N ₁ :N ₂) = 1:1					
Benennung - Note				drawing	Theiss	10.05.2012
			EWS Weigete GmbH & Co. KG Maybachstr. 1 D-73065 Ulmringen Tel. +49(0)7161/93040-10		DIN A2	
					File: D-EWS-120502-ldw Blatt - page 1 (1)	