

min. 103,5
max. 107

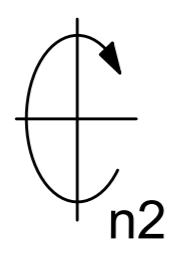

Spannzange / collet ER40 DIN6499
Spannbereich / clamping range: 3,0 - 26,0

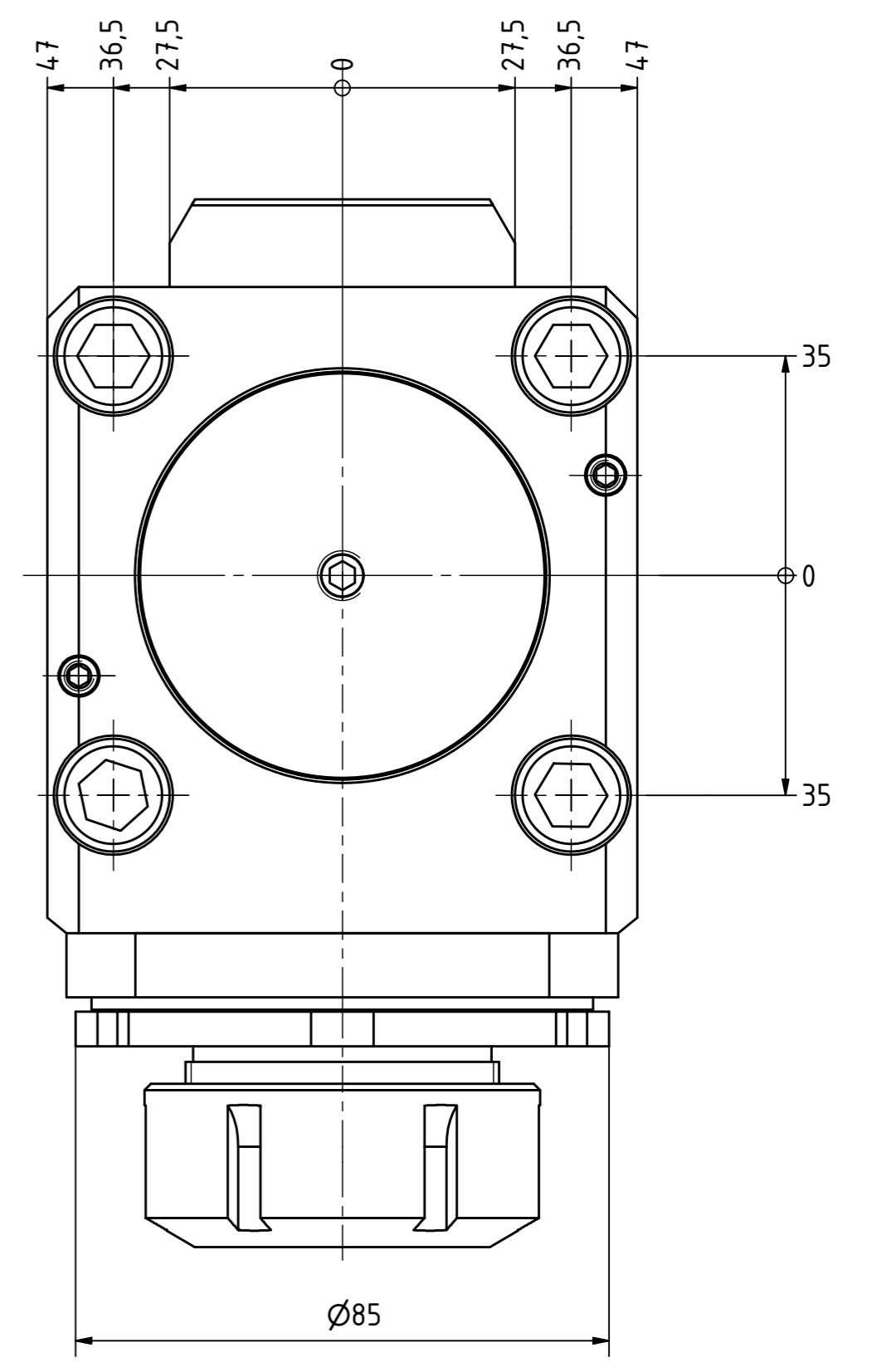
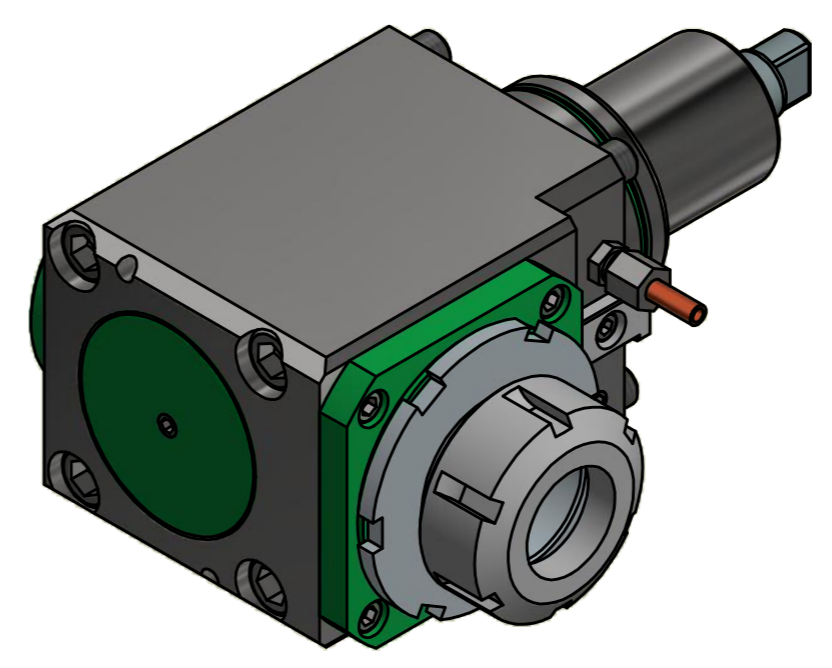

Gewindebohrzange / tapping collet
ET-1-40 M6-M16

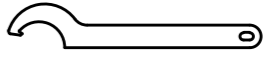

Hakenschlüssel
mit Nase
Hook wrench with
nose end
DIN1810 A 80x90

Spannzangenschlüssel
Clamping wrench
240

Copyright **EWS Tool Technologies**
Weitergabe und Vervielfältigung dieser Unterlage,
Verwertung und Mitteilung ihres Inhalts nicht
gestattet, soweit nicht ausdrücklich zugestanden.
Zu widerhandlungen verpflichten zu Schadenersatz.

Bemerkung - Note	Technische Daten - technical data Weight = 10.020 [kg] Torque max. (M1/M2) = 50 / 50 [Nm] Speed max. (n1/n2) = 6000 / 6000 [1/min] Gear ratio (i)=n1:n2 = 1:1	Benennung - Title Radial Bohr und Fräskopf <i>Radial drilling and milling head</i>	 EWS Weigle GmbH & Co. KG Maybachstr. 1 D-73066 Ulm/ingen www.ews-tool.de	Technische Änderungen vorbehalten! Subject to technical modifications! IDENT: DEWS118406 Nr. - No. 60.654.01809DW02GLX80	 REV: -/E MNR. 159030	
------------------	---	---	---	--	---	---