

Spannzange / collet ER40 DIN6499
Spannbereich / clamping range: 3,0 - 26,0

Innen- und Aussenkuehlung / Inside and outside coolant supply
Kuehlmittelfiltrierung 50μ / coolant filtration 50μ

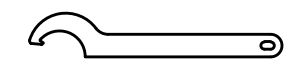

Hakenschlüssel
mit Nase
Hook wrench with
nose end
DIN1810 A 68x75

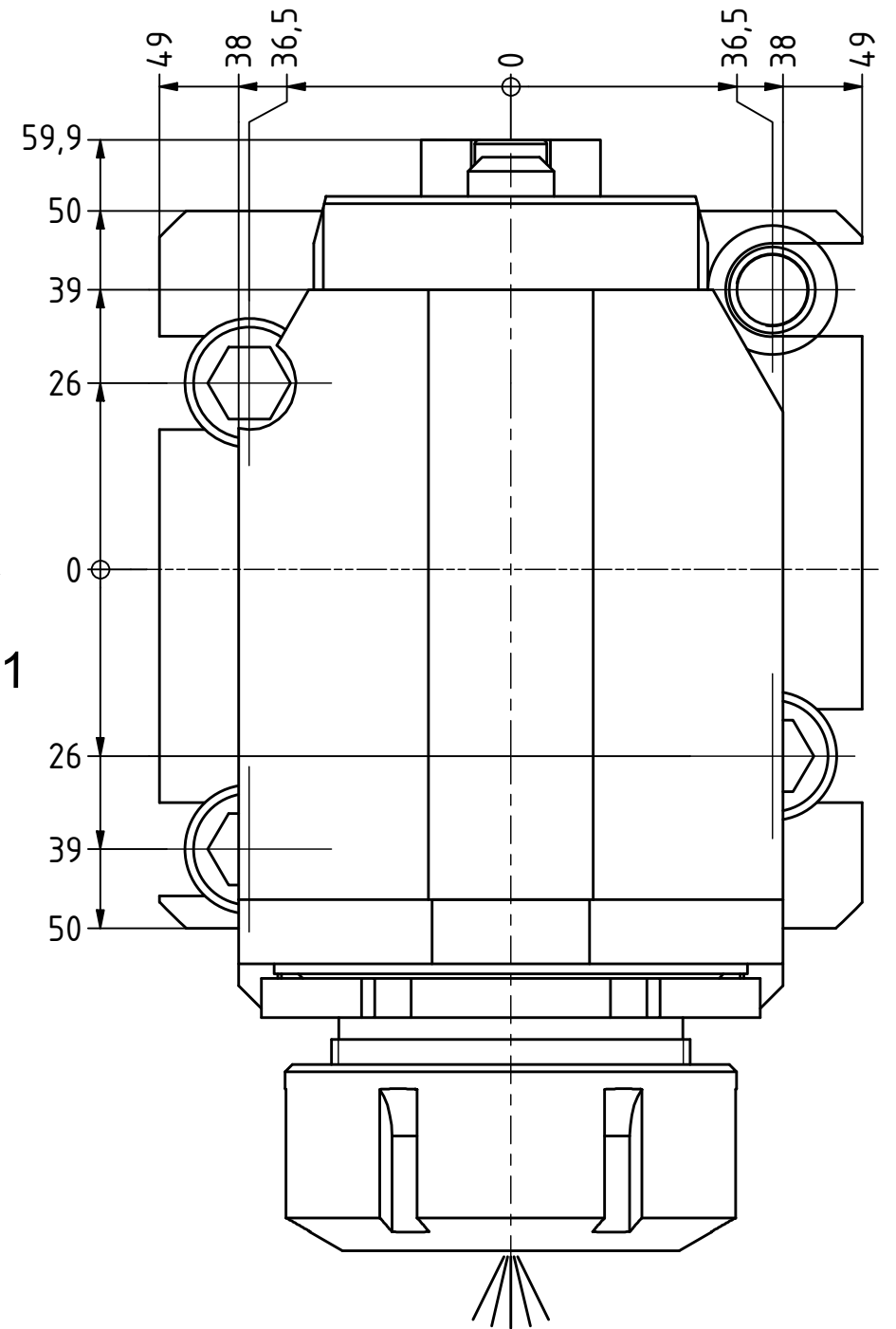

Spannzangenschlüssel
Clamping wrench
240

Copyright **EWS Tool Technologies**
Weitergabe und Vervielfaeltigung dieser Unterlage,
Verwertung und Mitteilung ihres Inhalts nicht
gestattet, soweit nicht ausdrecklich zugestanden.
Zuwiderhandlungen verpflichten zu Schadenersatz.

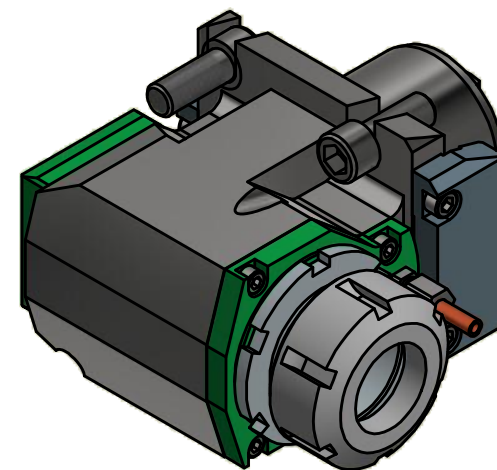

Bemerkung - Note
Für Trockenlauf geeignet!
Use without coolant fluid allowed!

Technische Daten - technical data
Weight = 5.725 [kg]
Torque max. (M1/M2) = 50 / 50 [Nm]
Speed max. (n1/n2) = 6000 / 6000 [1/min]
Gear ratio (i)=n1:n2 = 1:1
Pressure (pmax) = 70 [bar]

Benennung - Title
Radial Bohr und Fräskopf
Radial drilling and milling head



Nr. - No.
60.6040LB2000BMTIKD

Technische Aenderungen vorbehalten!
Subject to technical modifications!
IDENT: DEWS093907



REV: -/C

MNR.

157774

QR