

min. 80,5
max. 85

Ø50

Ø40

50

Spannzange / collet ER32 DIN6499
Spannbereich / clamping range: 2,0 - 20,0

Gewindebohrzange / tapping collet
ET-1-32 M5-M12

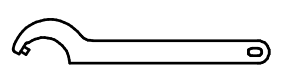

Hakenschlüssel
mit Zapfen
Hook wrench
with fixed pin
DIN1810 B 45x50



Spannzangenschlüssel
Clamping wrench
232

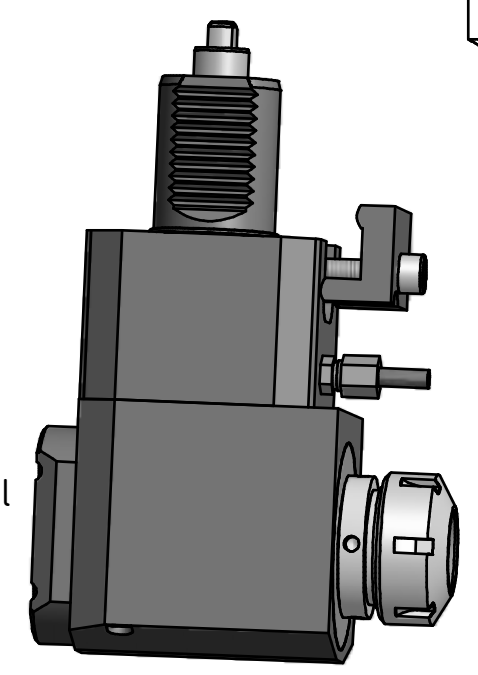

Copyright **EWS Tool Technologies**
Weitergabe und Vervielfaeltigung dieser Unterlage,
Verwertung und Mitteilung ihres Inhalts nicht
gestattet, soweit nicht ausdruuecklich zugestanden.
Zuwaiderhandlungen verpflichten zu Schadenersatz.

Bemerkung - Note	Technische Daten - technical data M1 / M2= 50 /50 Nm n1 / n2 = 6000 /6000 1/min i (N1:N2) = 1:1	Benennung - Title Radial Bohr und Fräskopf <i>Radial drilling and milling head</i>	name	date	Technische Aenderungen vorbehalten! Subject to technical modifications!	
			drawing	Schmid		
			Weigele GmbH & Co. KG Maybachstr. 1 D-73066 Uehingen Tel. +49(0)7161/93040-10		Nr. 60.4032V450R	DIN A3
			File: 60.4032V450_OUT.idw		Blatt - page 1 (1)	